

GEOMETRIC DESIGN CIVL 3161

Reading Assignment: p. 45-72 (4th ed.) p.45-75 (previous ed.) in *Manning textbook*.

Geometric design of highway facilities deals with the proportion of physical elements of highways, such as vertical and horizontal curves, lane widths, clearances, cross-section dimensions, etc.

Physical dimensions of geometric design elements are determined by:

- Characteristics of driver
- Characteristics of vehicle
- Characteristics of road

AASHTO – American Association of State Highway and Transportation Officials publishes *A Policy on Geometric Design of Highways and Streets*.

Factors Influencing Highway Design:

- Functional classification of highway being designed
 - Principal arterials
 - Minor arterials
 - Collectors
 - Local roads
- Expected traffic volume and vehicle mix
 - Volume: design for 30th highest hourly volume
 - Vehicle mix: proportion of passenger cars, heavy vehicles
- Design speed
- Topography of area in which highway will be located
- LOS to be provided
- Available funds
- Safety
- Social and environmental factors

We will discuss the design of both vertical and horizontal features of a roadway.

Design of Vertical Curves

A parabolic curve is the most common type used to connect two vertical tangents.

$$y = ax^2 + bx + c$$

y = roadway elevation at distance x from the PVC

x = distance from the PVC

c = elevation of PVC

b = G₁

$$a = \frac{G_2 - G_1}{2L}$$

*horizontal distances typically expressed in station format.

Two types of vertical curves:

- Crest
- Sag

Definitions:

PVI = Point of vertical intersection of tangent lines

PVC = Point of vertical curvature

PVT = Point of vertical tangency

L = Length of curve

G₁ = initial roadway grade in percent

G₂ = final roadway grade in percent

A = absolute value of difference in grades

Vertical Curve Offsets

Offset – vertical distance from initial tangent to the curve.

Relationships:

$$Y = \frac{A}{200L} x^2$$

where

Y = vertical offset at any distance x from the PVC
x = distance from PVC

$$K = \frac{L}{A}$$

where

K = horizontal distance required to achieve a 1% change in the slope of the vertical curve.

$$x_{hl} = K \times |G_1|$$

where

x_{hl} = distance from the PVC to the high or low point of the curve

Example: Crest Vertical Curve (3.2 in textbook)

A 500 ft long equal tangent crest vertical curve connects tangents that intersect at station 340 + 00 and elevation 1322 ft. The initial grade is +4.0% and the final grade is -2.5%. Determine the elevation and stationing of the high point, PVC, and PVT.

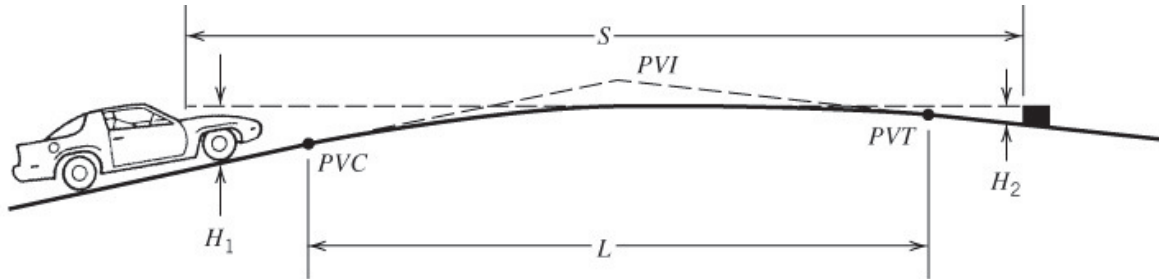

Example: Sag Vertical Curve (3.1 in textbook)

A 1600 ft long sag vertical curve (equal tangent) has a PVC at station 120 + 00 and elevation 1500 ft. The initial grade is -3.5% and the final grade is +6.5%. Determine the elevation and stationing of the low point, PVI, and PVT.

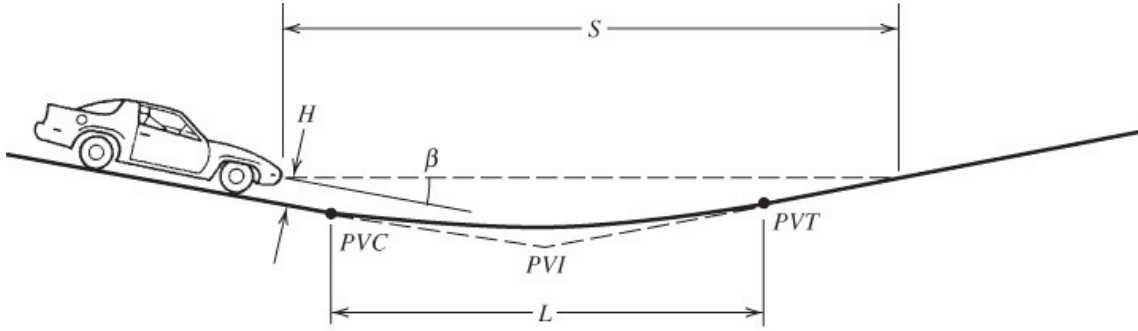

Stopping Sight Distance for Crest Vertical Curve:

- Based on driver eye height above roadway and height of object above roadway surface.
- Minimum length of curve that will provide adequate safety and minimum cost is desired.

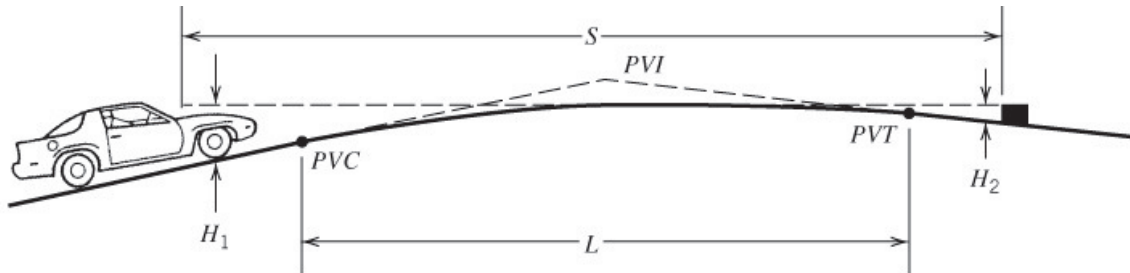

where:

H_1 = Driver eye height above roadway surface

H_2 = Height of object above roadway surface

Stopping Sight Distance for Sag Vertical Curve:

- Sight distance is governed by nighttime conditions.
- We are concerned with height of headlight above roadway and inclined angle of headlight beam.

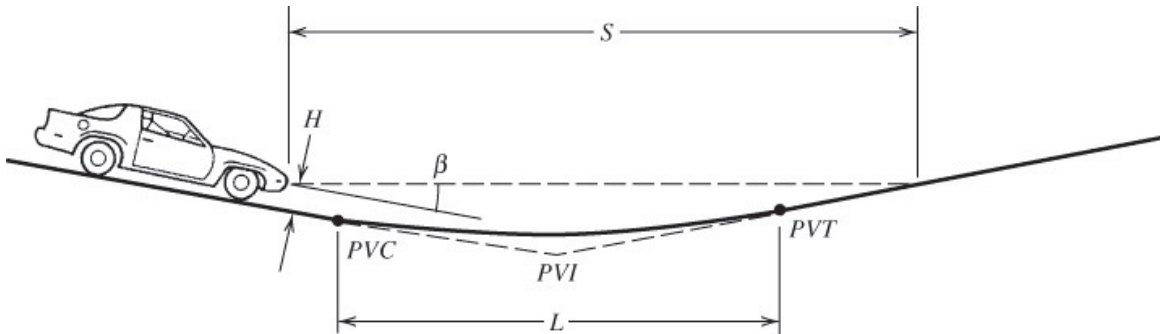

where:

H = height of headlight above road surface

β = inclined angle of headlight beam.

Equations from FE Review Manual:

TRANSPORTATION

Stopping Sight Distance

U.S. Customary Units Equation

$$S = \frac{V^2}{30[(a/32.2) \pm G]} + 1.47Vt$$

Metric Equation:

$$S = \frac{V^2}{254[(a/9.81) \pm G]} + 0.278Vt,$$

where (as appropriate):

- S = stopping sight distance (ft or m),
- G = percent grade divided by 100,
- V = design speed (mph or km/h),
- a = deceleration rate (ft/s² or m/s²),
= 11.2 ft/s² = 3.4 m/s² and
- t = driver reaction time (s).

Sight Distance Related to Curve Length

a. Crest Vertical Curve (general equations):

$$L = \frac{AS^2}{200(\sqrt{h_1} + \sqrt{h_2})^2} \quad \text{for } S \leq L$$

$$L = 2S - \frac{200(\sqrt{h_1} + \sqrt{h_2})^2}{A} \quad \text{for } S > L$$

where

- L = length of vertical curve (ft or m),
- A = algebraic difference in grades (%),
- S = sight distance for stopping or passing, (ft or m),
- h_1 = height of drivers' eyes above the roadway surface (ft or m), and
- h_2 = height of object above the roadway surface (ft or m).

U.S. Customary Units:

When $h_1 = 3.50$ ft and $h_2 = 2.0$ ft,

$$L = \frac{AS^2}{2,158} \quad \text{for } S \leq L$$

$$L = 2S - \frac{2,158}{A} \quad \text{for } S > L$$

Metric Units:

When $h_1 = 1,080$ mm and $h_2 = 600$ mm,

$$L = \frac{AS^2}{658} \quad \text{for } S \leq L$$

$$L = 2S - \frac{658}{A} \quad \text{for } S > L$$

b. Sag Vertical Curve (based on standard headlight criteria):

U.S. Customary Units

$$L = \frac{AS^2}{400 + 3.5S} \quad \text{for } S \leq L$$

$$L = 2S - \frac{400 + 3.5A}{A} \quad \text{for } S > L$$

Metric Units

$$L = \frac{AS^2}{120 + 3.5S} \quad \text{for } S \leq L$$

$$L = 2S - \frac{120 + 3.5A}{A} \quad \text{for } S > L$$

c. Sag Vertical Curve (based on adequate sight distance under an overhead structure to see an object beyond a sag vertical curve)

$$L = \frac{AS^2}{800} \left(C - \frac{h_1 + h_2}{2} \right)^{-1} \quad \text{for } S \leq L$$

$$L = 2S - \frac{800}{A} \left(C - \frac{h_1 + h_2}{2} \right) \quad \text{for } S > L$$

where

C = vertical clearance for overhead structure (underpass) located within 200 ft (60 m) of the midpoint of the curve (ft or m).

d. Sag Vertical Curve (based on riding comfort):

U.S. Customary Units

$$L = \frac{AV^2}{46.5}$$

Metric Units

$$L = \frac{AV^2}{395}$$

where (as appropriate):

L = length of vertical curve (ft or m),
 V = design speed (mph or km/hr), and
 A = algebraic difference in grades (%)

e. Horizontal curve (to see around obstruction):

$$M = R \left[1 - \cos \left(\frac{28.65S}{R} \right) \right]$$

where

R = radius (ft or m)
 M = middle ordinate (ft or m),
 S = stopping sight distance (ft or m).

Superelevation of Horizontal Curves

a. Highways:

U.S. Customary Units:

$$\frac{e}{100} + f = \frac{V^2}{15R}$$

Metric Units:

$$\frac{e}{100} + f = \frac{V^2}{127R}$$

where (as appropriate):

e = superelevation (%),
 f = side-friction factor,
 V = vehicle speed (mph or km/hr), and
 R = radius of curve (ft or m).

b. Railroads:

$$E = \frac{Gv^2}{gR}$$

where

E = equilibrium elevation of outer rail (in.),
 G = effective gage (center-to-center of rails) (in.),
 v = train speed (ft/s),
 g = acceleration of gravity (ft/s²), and
 R = radius of curve (ft).

Spiral Transitions to Horizontal Curves

a. Highways:

U.S. Customary Units:

$$L_s = \frac{3.15V^3}{RC}$$

Metric Units:

$$L_s = \frac{0.0214V^3}{RC}$$

where (as appropriate):

L_s = length of spiral (ft or m),
 V = design speed (mph or km/hr),
 R = curve radius (ft or m),
 C = rate of increase of lateral acceleration (ft/s³ or m/s³) = 1 ft/s³ = 0.3m/s³

b. Railroads:

$$L_s = 62E$$

$$E = 0.0007V^2D$$

where

L_s = length of spiral (ft),
 E = equilibrium elevation of outer rail (in.),
 V = speed (mph),
 D = degree of curve.

Example: SSD for Crest Vertical Curve (3.7 in textbook)

A 1200 ft. equal tangent crest vertical curve is currently designed for 50 mi/hr. A civil engineering student contends that 60 mph is safe in a van because of the higher driver's eye height. If all other design inputs are standard, what must the driver's eye height in the van be for the student's claim to be valid?

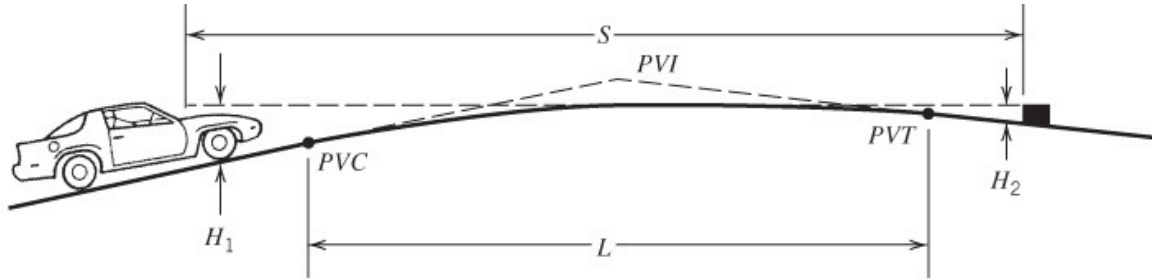

Example: SSD for Sag Vertical Curve (3.5 in textbook)

An equal tangent sag vertical curve is designed with the PVC at station 109 + 00 and elevation 950 ft, the PVI at station 110 + 77 and elevation 947.34 ft, and the low point at station 110 + 50 ft. Determine the design speed of the curve.

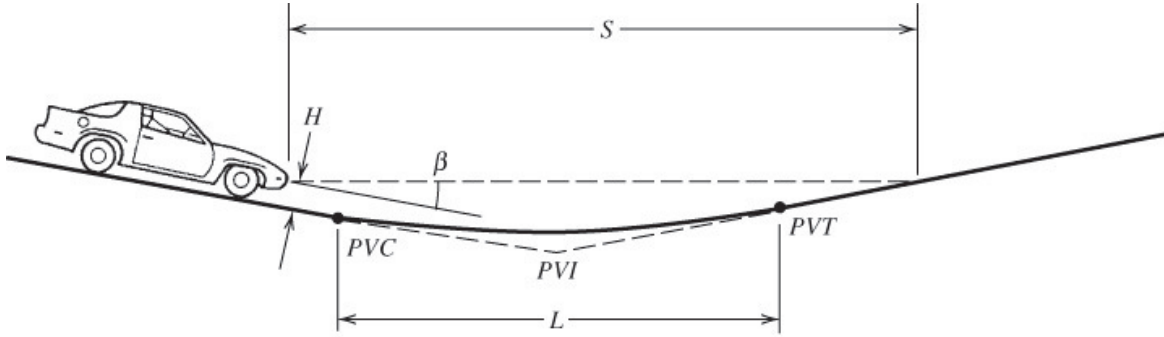

Horizontal Curves

Reading Assignment: pg. 75-86

Four types of horizontal curves:

Simple - curve with single constant radius.

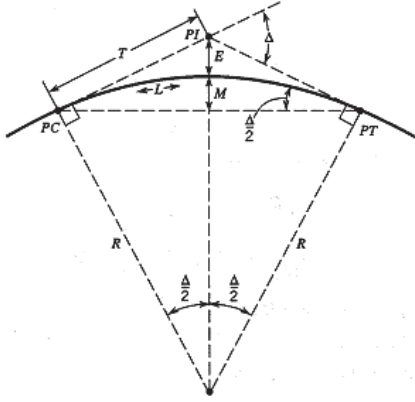

Compound – two or more curves in succession, turning in the same direction.

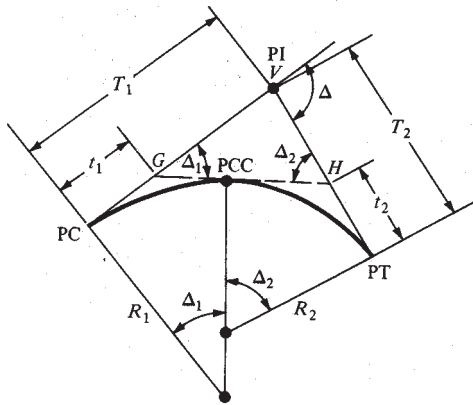

Reverse – two simple curves with equal radii turning in opposite directions with a common tangent.

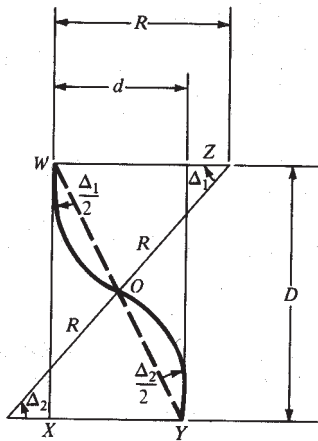

Spiral – also called transition curves; placed between tangents and circular curves or between two adjacent circular curves having substantially different radii.

With transition curves

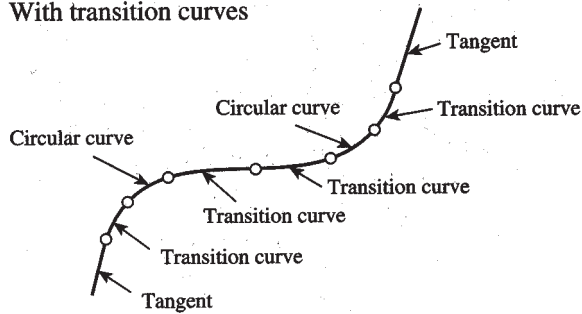

Without transition curves

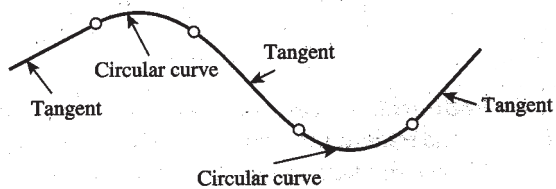

Horizontal Curve Formulas

Degree of Curve (D) – angle subtended by 100 ft arc along horizontal curve. Measure of “sharpness” of curve.

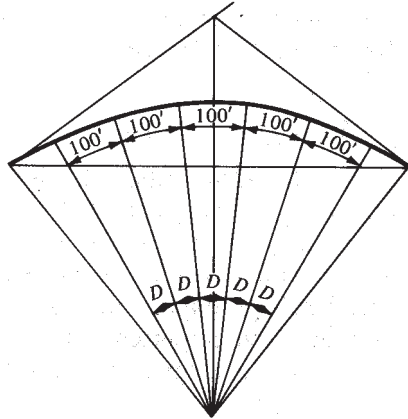

$$D = \frac{100 \left(\frac{180}{\pi} \right)}{R} = \frac{18000}{\pi R}$$

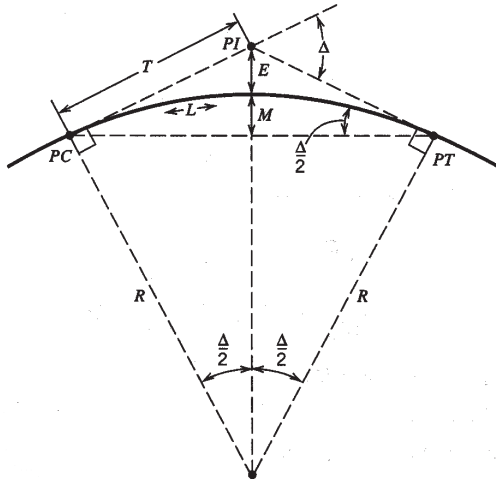

Figure 3.13 Elements of a simple circular horizontal curve.

In this figure,

R = radius, usually measured to the centerline of the road, in ft (m),

Δ = central angle of the curve in degrees,

PC = point of curve (the beginning point of the horizontal curve),

PI = point of tangent intersection,

PT = point of tangent (the ending point of the horizontal curve),

T = tangent length in ft (m),

M = middle ordinate in ft (m),

E = external distance in ft (m), and

L = length of curve in ft (m).

Figure 3.13 from your Mannering text.

$$T = R \tan \frac{\Delta}{2}$$

$$E = R \left[\frac{1}{\cos(\Delta/2)} - 1 \right]$$

$$M = R \left(1 - \cos \frac{\Delta}{2} \right)$$

$$L = \frac{\pi}{180} R \Delta$$

Example:

A horizontal curve is designed with a 1500 ft radius. The curve has a tangent length of 500 ft and the PI is at station 205 + 00 ft. Determine the stationing of the PT.

Superelevation of Horizontal Curves

The purpose of superelevation or “banking” of curves is to counteract the centripetal acceleration produced as a vehicle rounds a curve. Superelevation is the inclination of the roadway toward the center of the curve.

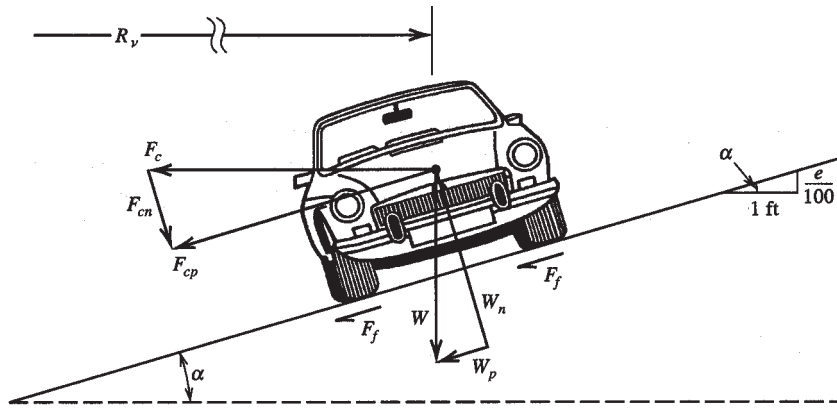

In this figure,

R_v = radius defined to the vehicle's traveled path in ft (m),

α = angle of incline in degrees,

e = number of vertical ft (m) of rise per 100 ft (m) of horizontal distance,

W = weight of the vehicle in lb (N),

W_n = vehicle weight normal to the roadway surface in lb (N),

W_p = vehicle weight parallel to the roadway surface in lb (N),

F_f = side frictional force [centripetal, in lb (N)],

F_c = centripetal force [lateral acceleration \times mass, in lb (N)],

F_{cp} = centripetal force acting parallel to the roadway surface in lb (N), and,

F_{cn} = centripetal force acting normal to the roadway surface in lb (N).

(Figure 3.12 from your Mannering text)

$$R_v = \frac{V^2}{g \left(f_s + \frac{e}{100} \right)} \quad (\text{Equation from Mannering})$$

$$\frac{e}{100} + f_s = \frac{V^2}{15R_v} \quad (\text{FE Manual equation}) \quad \text{***In this equation, } V \text{ is in mph!!}$$

– The location of a highway (rural or urban), the weather conditions, and the distribution of slow-moving traffic are all factors controlling the maximum value for the rate of superelevation. In general, for highways located in rural areas with no snow or ice, a maximum e of 0.10 is used. In areas with snow or ice, e ranges from 0.08-0.10. For urban highways, a maximum e of 0.08 is used.

Example:

Two rural highway tangents in Colorado intersecting at an angle of 20 degrees are to be connected by a circular horizontal curve. For a design speed of 70 mph, find:

- a.) radius
- b.) length of curve
- c.) external distance
- d.) length of tangent

Example:

A horizontal curve on a single-lane highway has its PC at station 124 + 10 and its PI at station 131 + 40. The curve has a superelevation of 0.06 ft/ft and is designed for 70 mph. What is the station of the PT?

Stopping Sight Distance in Horizontal Curve Design

It is necessary to consider provision of safe stopping sight distance in the design of horizontal curves, as well. If a vehicle is traveling along a horizontal curve, and an object is located on the inside edge of a roadway, it may obstruct a driver's view, resulting in reduced sight distance. Thus, minimum radii or curve lengths for highways with horizontal curves are determined based on required stopping sight distance.

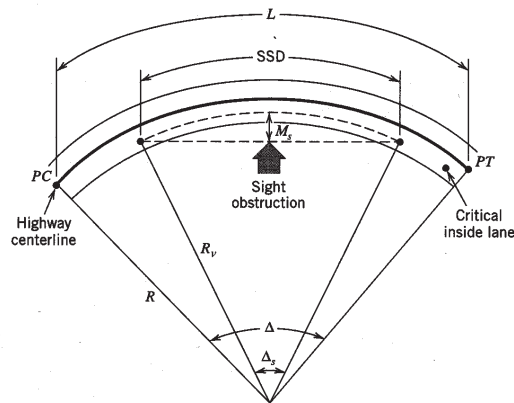

Figure 3.14 Stopping sight distance considerations for horizontal curves.

In this figure,

- | | |
|---|--|
| L = length of curve in ft (m), | Δ = central angle of the curve in degrees, |
| SSD = stopping sight distance in ft (m), | Δ_s = angle (in degrees) subtended by an arc equal in length to the required stopping sight distance (SSD), and |
| R = radius measured to the centerline of the road in ft (m), | M_s = middle ordinate necessary to provide adequate stopping sight distance (SSD) in ft (m). |
| R_v = radius to the vehicle's traveled path (usually measured to the center of the innermost lane of the road) in ft (m), | |
| PC = point of curve (the beginning point of the horizontal curve), | |
| PT = point of tangent (the ending point of the horizontal curve), | |

Figure 3.14 Mannering text.

From FE manual:

e. Horizontal curve (to see around obstruction):

$$M = R \left[1 - \cos \left(\frac{28.65 S}{R} \right) \right]$$

where

- R = radius (ft or m)
 M = middle ordinate (ft or m).
 S = stopping sight distance (ft or m).

* R in this equation is the same as R_v in your textbook. M is the same as M_s .

Example:

A horizontal curve on a single-lane freeway ramp is 400 ft long, and the design speed of the ramp is 45 mph. If the superelevation is 10% how much distance must be cleared from the center of the lane to provide adequate stopping sight distance?

Example:

A freeway exit ramp has a single lane and consists entirely of a horizontal curve with a central angle of 90 degrees and a length of 628 ft. If the distance cleared from the centerline for sight distance is 19.4 ft, what design speed was used?

Example:

A section of highway has vertical and horizontal curves with the same design speed. A vertical curve on this highway connects a +1% and a +3% grade and is 420 ft long. If a horizontal curve on this highway is on a two-lane section with 12-ft lanes, has a central angle of 37 degrees, and has a superelevation of 6%, what is the length of the horizontal curve?

Spiral Transitions to Horizontal Curves:

Transition curves- used between tangents and circular curves or between two circular curves that have significantly different radii.

To calculate the minimum length of spiral curve necessary:

$$L_s = \frac{3.15V^3}{RC}$$

Where:

L_s = length of spiral (ft)

V = design speed (**mph**)

R = curve radius (ft)

C = rate of increase of lateral acceleration (ft/s³) *design value = 1 ft/s³

Example: Given a horizontal curve with a 1360 ft radius, estimate the minimum length of spiral necessary for a smooth transition from tangent alignment to the circular curve. The design speed is 65 mph.

Superelevation of Railway Curves:

Railways should be designed such that equilibrium exists during travel (both wheels bear equally on the rails). The equilibrium elevation can be calculated using the following equation:

$$E = 3.97V^2 / R$$

Where

V = speed (**mph**)

R = radius of curve (**ft.**)

Relationship between Degree of Curve and Radius(chord definition): $\sin \frac{1}{2} D = \frac{50}{R}$

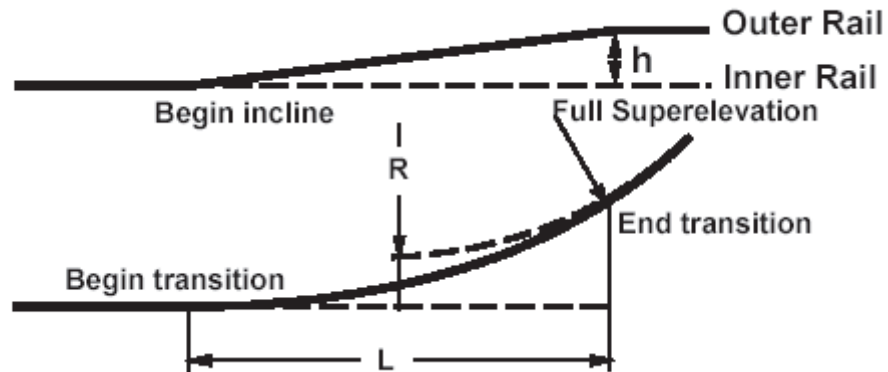

Equilibrium elevations based on varying speeds have been calculated by the American Railway Engineering Association (AREA), and are presented in the table below.

Table 12-6A Equilibrium Elevation for Various Speeds on Curves

| Degree of Curve | 30 mph | 40 mph | 50 mph | 60 mph | 70 mph | 80 mph |
|-----------------|--------|--------|--------|--------|--------|--------|
| 0°30' | 0.32 | 0.56 | 0.88 | 1.26 | 1.72 | 2.24 |
| 1°00' | 0.63 | 1.12 | 1.75 | 2.52 | 3.43 | 4.48 |
| 1°30' | 0.95 | 1.68 | 2.63 | 3.78 | 5.15 | 6.72 |
| 2°00' | 1.26 | 2.24 | 3.50 | 5.04 | 6.86 | 8.96 |
| 2°30' | 1.58 | 2.80 | 4.38 | 6.30 | 8.58 | 11.20 |
| 3°00' | 1.89 | 3.36 | 5.25 | 7.56 | 10.29 | |
| 3°30' | 2.21 | 3.92 | 6.13 | 8.82 | | |
| 4°00' | 2.52 | 4.48 | 7.00 | 10.08 | | |
| 5°00' | 3.15 | 5.60 | 8.75 | | | |
| 6°00' | 3.78 | 6.72 | 10.50 | | | |
| 7°00' | 4.41 | 7.84 | | | | |
| 8°00' | 5.04 | 8.96 | | | | |
| 9°00' | 5.67 | 10.08 | | | | |
| 10°00' | 6.30 | 11.20 | | | | |
| 11°00' | 6.93 | | | | | |
| 12°00' | 7.56 | | | | | |

Note: E in inches = $0.0007V^2D$, where E = equilibrium elevation, V = speed, and D = degree of curve.

Source: *Manual of Recommended Practice*, American Railway Engineering Association, Washington, DC, 1995.

Example:

Determine the equilibrium elevation, in inches, for a 1° 45' railroad curve given a design speed of 60 mph.

Spiral Transitions for Railroads:

AREA recommends the use of spiral curves on all mainline tracks between curves in the case of compound curves, and between tangent and curve for all other circular curves.

To calculate the minimum length of spiral for rail systems:

$$L_s = 62E$$

$$E = 0.0007V^2D$$

Where:

L_s = length of spiral (**ft.**)

E = equilibrium elevation of outer rail (**in.**)

V = speed (**mph**)

D = degree of curve)(*chord definition)

*for curves less than 4°, can assume 100 ft. chord = 100 ft. arc.

Example:

It is the policy of a certain urban railroad to use a 7-in. maximum elevation of the outer rail. Given a 75 mph maximum speed and a 2.5° of curve, determine the superelevation that should be used and the minimum length of spiral.