

# **GEOTECHNICAL ENGINEERING FORMULAS**

**A handy reference for use in geotechnical analysis and design**

# TABLE OF CONTENTS

Page

<b>1. SOIL CLASSIFICATION</b> .....	3
<b>1.1 USCS: Unified Soil Classification System</b> .....	3
1.1.1 Relative Density of Cohesionless Soils: .....	4
1.1.2 Fine Grained(Cohesive) Soil Charts using the USCS System:..	4
1.1.3 Consistency of Fine Grained Soils: .....	5
1.2 USDA Soil Classification System .....	5
1.3 AASHTO Soil Classification System:.....	6
<b>2. PHASE RELATIONSHIP EQUATIONS:</b> .....	7
2.1 Shear Strength of Soils .....	7
2.2 Bearing Capacity of Soils .....	7
<b>3. STRESSES IN SOILS</b> .....	9
3.1 Various Loading Conditions:.....	9
.....	9
.....	9
<b>4. SHALLOW FOUNDATIONS</b> .....	10
4.1 Conventional Footings.....	10
4.11 Geotechnical Analysis.....	10
4.12 Structural Design:.....	10
4.2 Strap or Cantilever Footings:.....	11
4.3 Trapezoidal Footings: .....	12
<b>5. SOIL CONSOLIDATION EQUATIONS</b> .....	14
5.1 Instant Settlement of footings:.....	14
5.2 Primary Consolidation: .....	14
5.3 Overconsolidated Soils .....	14
5.4 Time rate of settlement .....	15
5.41 Coefficient of consolidation.....	15
<b>6. RETAINING STRUCTURES:</b> .....	16
6.1 Horizontal Stresses: Active, At Rest and Passive.....	16
6.2 Basement Wall with surcharge: .....	17
6.3 Braced Excavations:.....	17
6.4 Forces on Struts:.....	18
6.5 Cantilever Sheetpiles in Sand .....	20
6.6 Cantilever Sheetpiles in Clay .....	21
6.6 Anchored Sheetpiles in Sand (Also called Bulkheads) .....	22
6.7 Anchored Sheetpiles in Clay (Also called Bulkheads).....	24
<b>7. PILE FOUNDATIONS</b> .....	25
<b>8. Post Tensioned Slabs:</b> .....	28
<b>9. Asphalt Mix Design:</b> .....	30
<b>10. Concrete Mix Design:</b> .....	33

# 1. SOIL CLASSIFICATION

## 1.1 USCS: Unified Soil Classification System

Coarse Grained soils have less than 50% passing the # 200 sieve:

Symbol	Passing the #200	$Cu = \frac{D_{60}}{D_{30}}$	$Cc = \frac{(D_{30})^2}{D_{10} \times D_{60}}$	Soil Description
GW	< 5%	4 or higher	1 to 3	Well graded gravel
GP	< 5%	Less than 4	1 to 3	Poorly graded gravel
GW-GM	5 to 12%	4 or higher	1 to 3 but with <15% sand	Well graded gravel with silt
GW-GM	5 to 12%	4 or higher	1 to 3 but with $\geq$ 15% sand	Well graded gravel with silt and sand
GW-GC	5 to 12%	4 or higher	1 to 3 but with <15% sand	Well graded gravel with clay or silty clay
GW-GC	5 to 12%	4 or higher	1 to 3 but with $\geq$ 15% sand	Well graded gravel with clay and sand
GC	>12%	N/A	N/A, <15% sand	Clayey Gravel
GC	> 12%	N/A	N/A, >15% sand	Clayey Gravel with sand
GM-GC	>12%	N/A	N/A, <15% sand	Clayey Silt with gravel
GM-GC	>12%	N/A	N/A, $\geq$ 15% sand	Clayey Silt with sand
SW	< 5%	6 or higher	1 to 3	Well graded sand
SP	< 5%	Less than 6	1 to 3	Poorly graded sand
SM	>12%	N/A	N/A	Silty Sand or Sandy Silt
SC	>12%	N/A	N/A	Clayey Sand or Sandy Clay
SC-SM	>12%	N/A	N/A	Silty Clay with Sand

Where:

$Cu$  = Uniformity Coefficient; gives the range of grain sizes in a given sample. Higher  $Cu$  means well graded.

$Cz$  = Coefficient of Curvature is a measure of the smoothness of the gradation curve. Usually less than 3.

$D_{10}$ ,  $D_{30}$ , &  $D_{60}$  are the grain size diameter corresponding to 10%, 30% and 60% passing screen.

### 1.1.1 Relative Density of Cohesionless Soils:

SPT or N value	Relative Density	% Relative Density
0 – 3	Very loose	0 – 15
4 – 10	Loose	15 – 35
11 – 30	Medium dense	35 – 65
31 – 50	Dense	65 -85
> 50	Very dense	85 - 100

### 1.1.2 Fine Grained(Cohesive) Soil Charts using the USCS System:

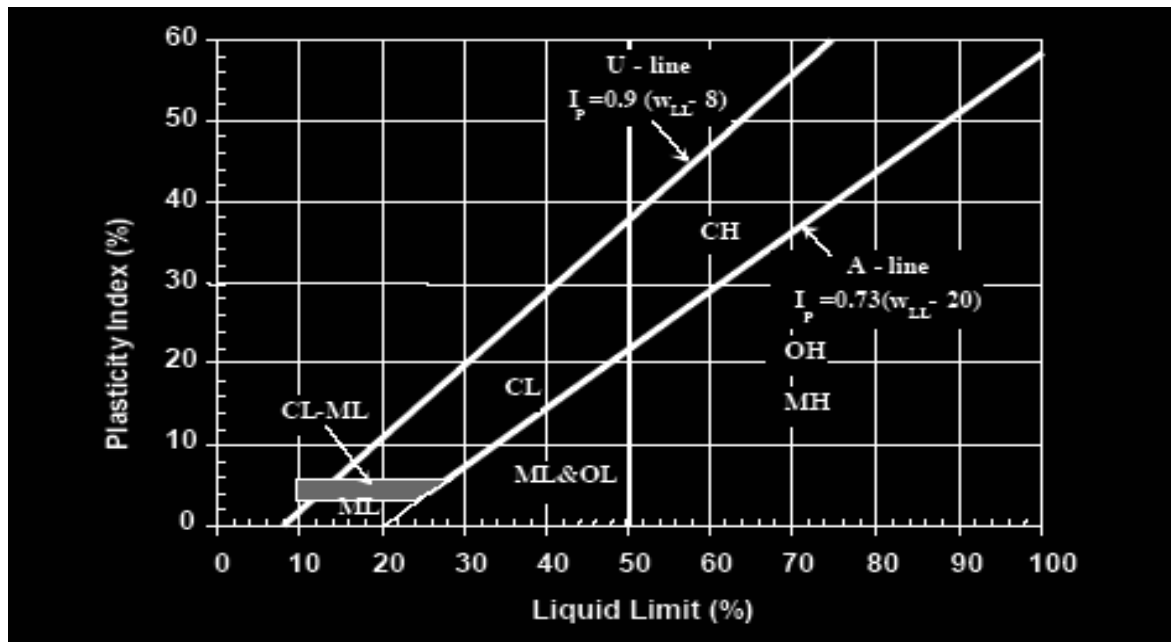

### 1.1.3 Consistency of Fine Grained Soils:

SPT or N value	Cohesion, C or Su	Consistency
< 2	< 500 psf	Very soft
2 – 4	500 – 1000 psf	Soft
5 – 8	1000 – 2000 psf	Firm
9 – 15	2000 – 4000 psf	Stiff
16-30	4000 – 8000 psf	Very stiff
>30	> 8000 psf	Hard

## 1.2 USDA Soil Classification System

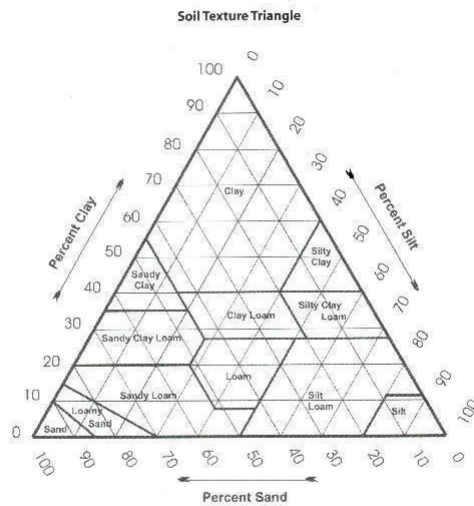

The percent SAND,SILT,and CLAY lines are drawn and their intersection gives the soil classification.

### 1.3 AASHTO Soil Classification System:

CLASSIFICATION OF HIGHWAY SUBGRADE MATERIALS (With suggested subgroups)											
General Classification	Granular Materials (35% or less passing No. 200)						Silt-Clay Materials (More than 35% passing #200)				
Group Classification	A-1		A-3	A-2				A-4	A-5	A-6	A-7 A-7-5 A-7-6
	A-1-a	A-1-b		A-2-4	A-2-5	A-2-6	A-2-7				
Sieve Analysis, Percent Passing:											
No. 10	0-50		51-100								
No. 40	0-30	0-50									
No. 200	0-15	0-25	0-10	0-35	0-35	0-35	0-35	36-100	36-100	36-100	36-100
Characteristics of fraction passing # 40:											
Liquid Limit				0-40	41+	0-40	41+	0-40	41+	0-40	41+
Plasticity Index	0-6		N.P.	0-10	0-10	11+	11+	0-10	0-10	11+	11+
Group Index	0		0	0		0-4		0-8	0-12	0-16	0-20
Usual Types of Significant Constituent Materials	Stone Fragments, Gravel and Sand		Fine Sand	Silty or Clayey Gravel and Sand				Silty Soils		Clayey Soils	
General Rating as Subgrade	Excellent to Good						Fair to Poor				

Cohesive soils classification in AASHTO System:

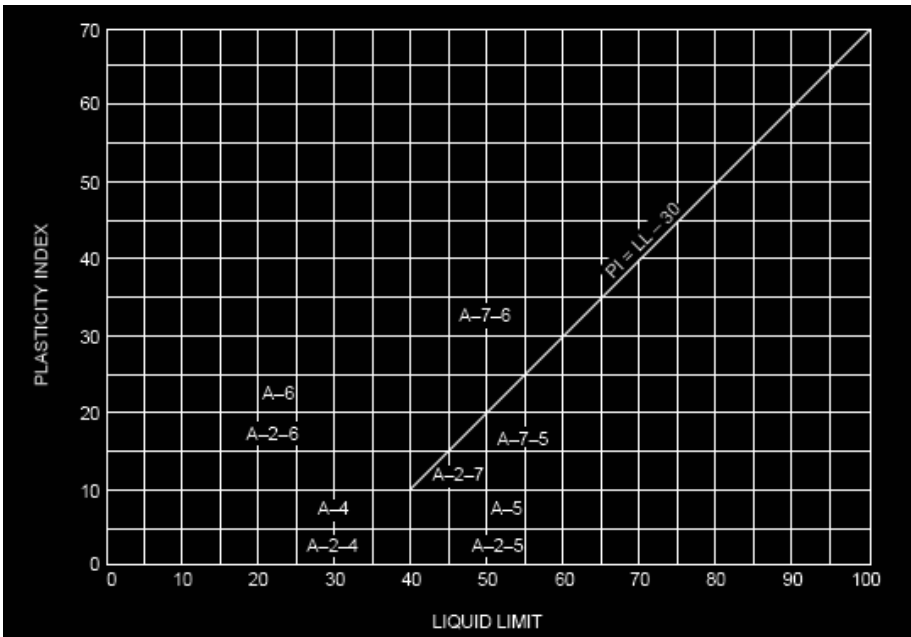

## 2. PHASE RELATIONSHIP EQUATIONS:

Dry Unit Weight, $\gamma_d$	Bulk or Wet or Total Unit Weight, $\gamma_m$ or $\gamma_w$ or $\gamma_t$ or $\gamma$	Saturated Unit Weight, $\gamma_s$ or $\gamma_{sat}$
$\gamma_d = \frac{\gamma}{1+w}$	$\frac{(1+w)G_s\gamma_w}{1+e}$	$\gamma_{sat} = \frac{(G_s+e)\gamma_w}{1+e}$
$\gamma_d = \frac{G_s\gamma_w}{1+e}$	$\frac{(G_s+Se)\gamma_w}{1+e}$	$\gamma_{sat} = \left(\frac{e}{w}\right)\left(\frac{1+w}{1+e}\right)\gamma_w$
$\gamma_d = \frac{eS\gamma_w}{(1+e)w}$	$\frac{(1+w)G_s\gamma_w}{1+\frac{wG_s}{S}}$	$\gamma_{sat} = [(1-n)G_s+n]\gamma_w$
$\gamma_d = G_s\gamma_w(1-n)$	$G_s\gamma_w(1-n)(1+w)$	$\gamma_{sat} = \gamma_d + \left(\frac{e}{1+e}\right)\gamma_w$

### 2.1 Shear Strength of Soils

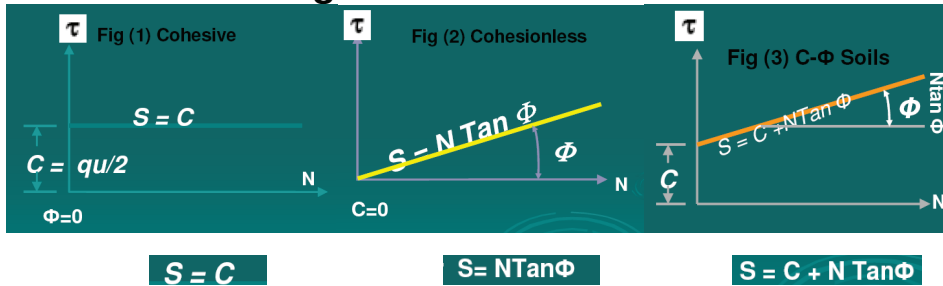

### 2.2 Bearing Capacity of Soils

Hansen B.C. Factors:

$\phi$	$N_c$	$N_q$	$N_\gamma$
0	5.10	1.00	0.00
4	6.19	1.43	0.05
8	7.53	2.06	0.22
12	9.28	2.97	0.63
16	11.63	4.34	1.43
20	14.83	6.40	2.95
24	19.32	9.60	5.75
26	22.25	11.85	7.94
28	25.80	14.72	10.94
30	30.14	18.40	15.07
32	35.49	23.18	20.79
34	42.16	29.44	28.77
36	50.59	37.75	40.05
38	61.35	48.93	56.18
40	75.32	64.20	79.54

### Terzaghi B.C. Factors

$\phi'$	$N_q$	$N_c$	$N_\gamma$
0	1.00	5.70	0.0
2	1.22	6.30	0.2
4	1.49	6.97	0.4
6	1.81	7.73	0.6
8	2.21	8.60	0.9
10	2.69	9.60	1.2
12	3.29	10.76	1.7
14	4.02	12.11	2.3
16	4.92	13.68	3.0
18	6.04	15.52	3.9
20	7.44	17.69	4.9
22	9.19	20.27	5.8
24	11.40	23.36	7.8
26	14.21	27.09	11.7
28	17.81	31.61	15.7
30	22.46	37.16	19.7
32	28.52	44.04	27.9
34	36.50	52.64	36.0
35	41.44	57.75	42.4
36	47.16	63.53	52.0
38	61.55	77.50	80.0
40	81.27	95.66	100.4
42	108.75	119.67	180.0
44	147.74	151.95	257.0
45	173.29	172.29	297.5

#### Allowable Gross Bearing Capacity- 9 Equations

##### In Cohesionless(granular) Soils

$$q_u = \gamma D(N_q) + 0.6\gamma R(N_\gamma) \text{--for circular footings}$$

$$q_u = \gamma D(N_q) + 0.4\gamma B(N_\gamma) \text{-- for square or rectangular footings}$$

$$q_u = \gamma D(N_q) + 0.5\gamma B(N_\gamma) \text{—for continuous footings}$$

##### In Cohesive (clayey) Soils

$$q_u = 1.3 C(N_c) + \gamma D \text{--for circular footings}$$

$$q_u = C N_c ( 1 + (0.3B/L) ) + \gamma D \text{-- for square or rectangular footings}$$

$$q_u = C N_c + \gamma D \text{—for continuous footings}$$

##### In Mixed soils (C- $\Phi$ )

$$q_u = 1.3C(N_c) + \gamma D(N_q) + 0.6\gamma R(N_\gamma) \text{--for circular footings}$$

$$q_u = C N_c ( 1 + (0.3B/L) ) + \gamma D(N_q) + 0.4 \gamma B(N_\gamma) \text{ - for sq/rect. footings}$$

$$q_u = C N_c + \gamma D N_q + 0.5 \gamma B(N_\gamma) \text{ —for continuous footings}$$

▼	▼	▼
Cohesion	Surcharge	Friction
1 <sup>st</sup> term	2 <sup>nd</sup> term	3 <sup>rd</sup> term



**Note:** If  $D_f/B > 1$ , Terzaghi's B.C. factors do not apply. Use Hansen's B.C. factors. For example, if depth of footing ( $D_f$ ) is 3 ft but footing width ( $B$ ) is 2.75 ft.

### 3. STRESSES IN SOILS

#### 3.1 Various Loading Conditions:

1) Stress due to concentrated or a Point load

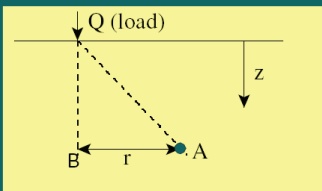

$$\Delta\sigma_v = \frac{Q}{Z^2} * \left[ \frac{3}{2\pi} \left[ 1 + \frac{r^2}{z^2} \right]^{5/2} \right] \text{ at point A}$$

The [ second term ] is IB-Boussinesq's influence coefficient and you may Plot  $r/z$  versus IB

$$\Delta\sigma_v = 0.4775 \left( \frac{Q}{Z^2} \right) \text{ at point B}$$

**NOTE:** This assumes that the soil profile is isotropic, homogeneous, elastic half-spaced material. Since soil properties vary in direction, is comprised of more than one type and is layered, Boussinesq's formula is Conservative But useful for getting upper bound solution.

2) Stress due to a line load:

$$\Delta\sigma_v = \frac{2q(Z^3)}{\pi(R^4)}$$

$q$  = line load in k/ft or similar  
 $R = (x^2 + z^2)^{0.5}$   
 $\Psi$  = Angle line R makes with the vertical axis

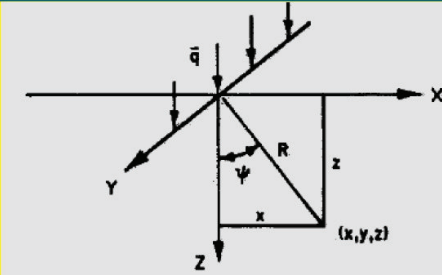

**Strip**

3)  $q$  = line load in ksf or similar

$$\Delta\sigma_v = \frac{q}{\pi} (\alpha + \sin\alpha \cos(\alpha + 2\beta))$$

Where:  
 $\alpha = \tan^{-1} \left( \frac{x+b}{z} \right) - \beta$   
 $\beta = \tan^{-1} \left( \frac{x-b}{z} \right)$

$\alpha$  &  $\beta$  are in Radians

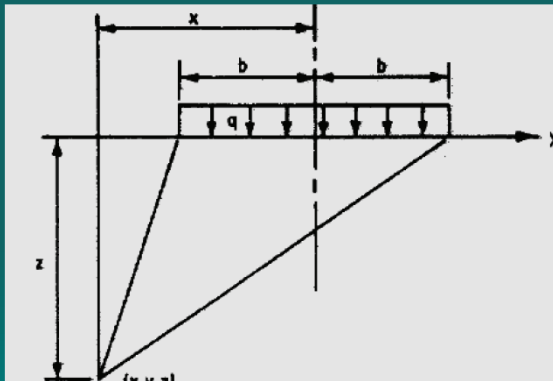

## 4. SHALLOW FOUNDATIONS

### 4.1 Conventional Footings

#### 4.1.1 Geotechnical Analysis

$q_{all} = Q / B \times 1$  for Continuous Footings

$q_{all} = Q / B \times L$  for Rectangular Footings

$q_{all} = Q / B \times B$  for Square Footings

$q_{all} < q_u / 3$  from Bearing Capacity Calculations

$e < B/6$ , where  $e$ =eccentricity

$D_f > 1.0$  ft minimum

$D_f >$  frost depth

$D_f >$  setback distance for footings on slope

$D_f >$  scour depth

$D_f >$  high moisture variations depth (expansive soils)

#### 4.1.2 Structural Design:

**Given: A Continuous footing with  $\gamma_m = 100$  pcf,  $D_f = 5$  ft,  $q_{all} = 4,000$  psf, D.L.=22 k/ft, L.L.=12 k/ft,  $f'_c=3$  ksi,  $f_y=60$  ksi. Design the footings using the ACI code:**

- 1.) Effective soil pressure: Assume total depth of footing = 19 in.

$$\text{Weight of footing} = (19)(150)/12 = 237.5 \text{ lb./ft.}^2$$

$$\text{Weight of soil} = (5-19/12)(100) = 341.7 \text{ lb./ft.}^2$$

$$q_e = 4000 - 238 - 342 = 3420 \text{ lb./ft.}^2 = 3.42 \text{ k/ft.}^2$$

- 2.) Width of footing = \_\_\_\_\_, **use 10 ft. footing.**

- 3.) Net upward pressure =  $P_u / \text{Area}$

$$P_u = 1.2D + 1.6L = (1.2)(22) + (1.6)(12) = 45.6 \text{ k/ft.}$$

$$q_u = 45.6 / (10 \cdot 1) = 4.56 \text{ k/ft.}$$

- 4.) Check one-way shear:  $d = 19 - 3.5 = 15.5$  in.

$$V_u = q_u \left( \frac{L}{2} - \frac{a}{2} - d \right) = 4.56 \left( \frac{10}{2} - \frac{12}{2 \cdot 12} - \frac{15.5}{12} \right) = 14.63 \text{ kip}$$

$$d = \frac{V_u}{\phi 2 \sqrt{f'_c} b} = \frac{14.63 \cdot 1000}{0.75 \cdot 2 \sqrt{3000} \cdot 12} = 14.8 \text{ in.} < 15.5 \text{ in.}$$

**use actual  $d = 15.5$  in.**

- 5.) Calculate  $B.M.$  and  $A_s$ :

$$M_u = \frac{q_u}{2} \left( \frac{L}{2} - \frac{a}{2} \right)^2 = \frac{4.56}{2} \left( \frac{10}{2} - \frac{12}{2 \cdot 12} \right)^2 = 46.17 \text{ k.ft.}$$

, Assume  $a = 1.5$  in.

$$A_s = \frac{M_u}{\phi f_y \left( d - \frac{a}{2} \right)} = \frac{46.17 \cdot 12}{0.9 \cdot 60 \left( 15.5 - \frac{1.5}{2} \right)} = 0.7 \text{ in.}^2$$

$$a = \frac{A_s f_y}{0.85 f'_c b} = \frac{0.7 \cdot 60}{0.85 \cdot 3 \cdot 12} = 1.364 \text{ in., o.k.}$$

Check

$$A_{s(\min)} = 0.0018bh = (0.0018)(12)(19) = 0.41 \text{ in.}^2 < 0.70 \text{ in.}^2$$

**Use #7 bars @ 9 in. ( $A_s = 0.80 \text{ in.}^2$ )**

- 6.)  $l_{dev}$  = available development length =  $(10 \cdot 12/2) - (12/2) - 3 = 51$  in.

Required  $l_d = 48$  in.  $< 51$  in. ( $l_d$  from Table 7.2, chapter 7)

- 7.) Longitudinal reinforcement =  $A_{s(\min)} = 0.41 \text{ in.}^2$ , **use #5 bars @ 9 in. ( $A_s = 0.41 \text{ in.}^2$ )**

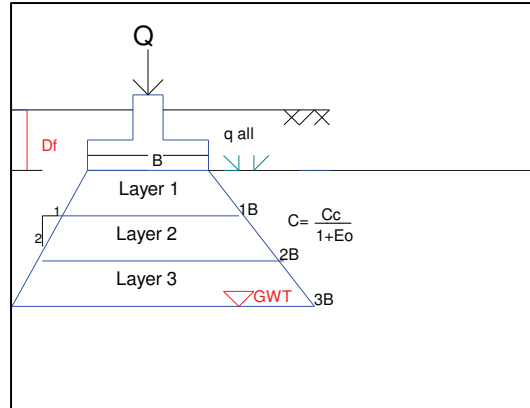

## 4.2 Strap or Cantilever Footings:

Strap Footing with varying beam thickness

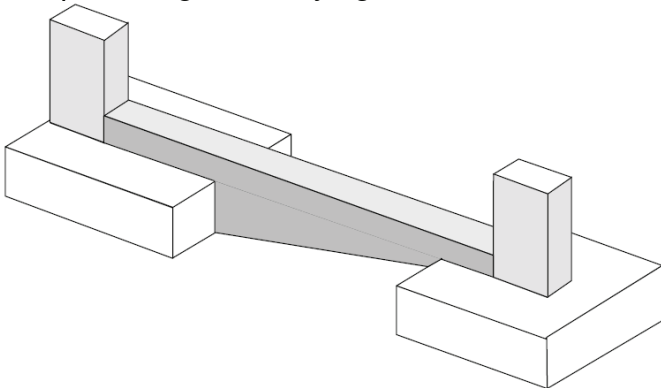

Strap Footings with constant beam thickness

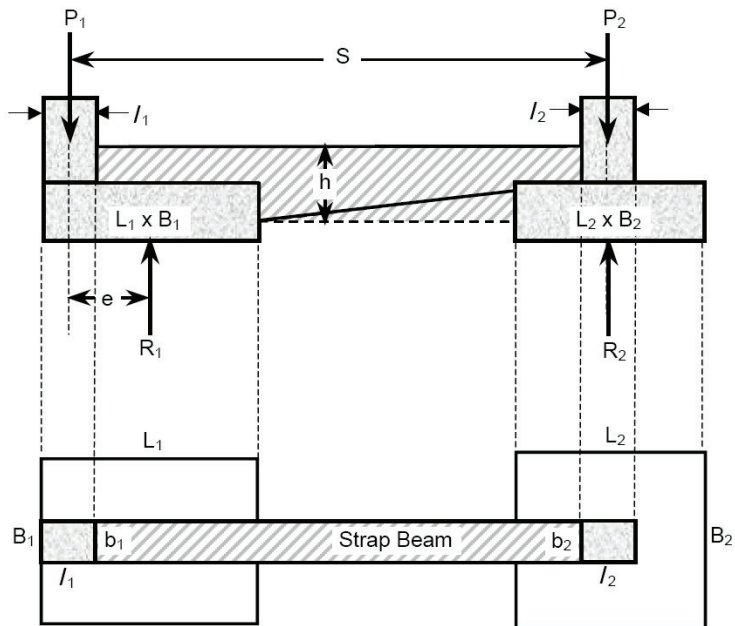
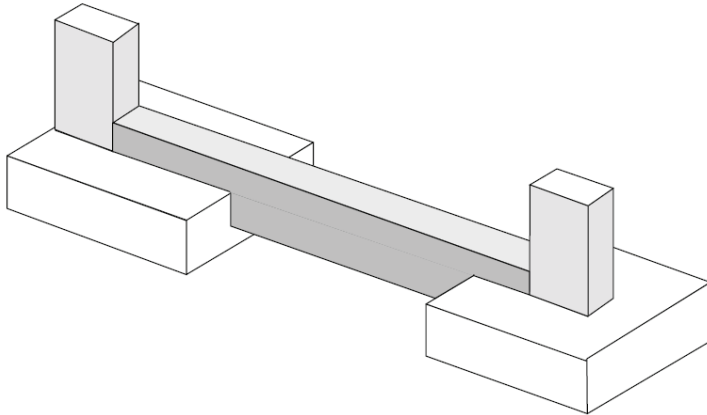

DIMENSION FOOTINGS (Determine  $L_1, B_1, L_2$  and  $B_2$ )

Allowable load  $P = P_1 + P_2$

Ultimate load  $P_u = [1.4DL_1 + 1.7LL_1] + [1.4DL_2 + 1.7LL_2]$

Ultimate ratio  $r_u = \frac{P_u}{P}$  , Ultimate applied pressure  $q_u = q_a \times r_u$

$\Sigma M_{col.2} = 0$

$R_1 (S - e) - P_{u1} S = 0$  ..... (1)

$\Sigma M_{R1} = 0$

$P_{u2} (S - e) - R_2 (S - e) - P_{u1} e = 0$  ..... (2)

$\Sigma F = 0$

$P_{u1} + P_{u2} - R_1 - R_2 = 0$  ..... (3)

$q_u = r_u q_a$

Footing 1:  $L_1 = 2 \times \left( e + \frac{l_1}{2} \right)$  and  $B_1 = \frac{R_1}{q_u L_1}$

Footing 2: let  $k_2 = \frac{L_2}{B_2}$  (1.0 means footing 2 is square)

$B_2 = \sqrt{\frac{R_2}{k_2 q_u}}$  and  $L_2 = k_2 B_2$

**4.3 Trapezoidal Footings:**

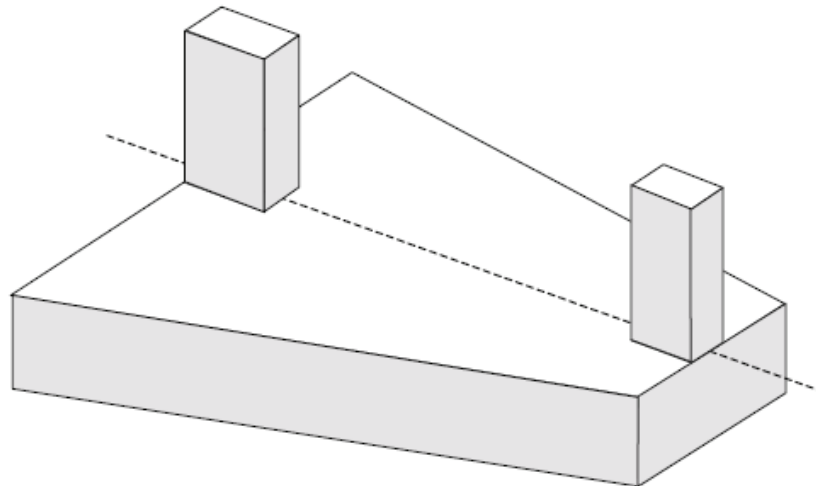

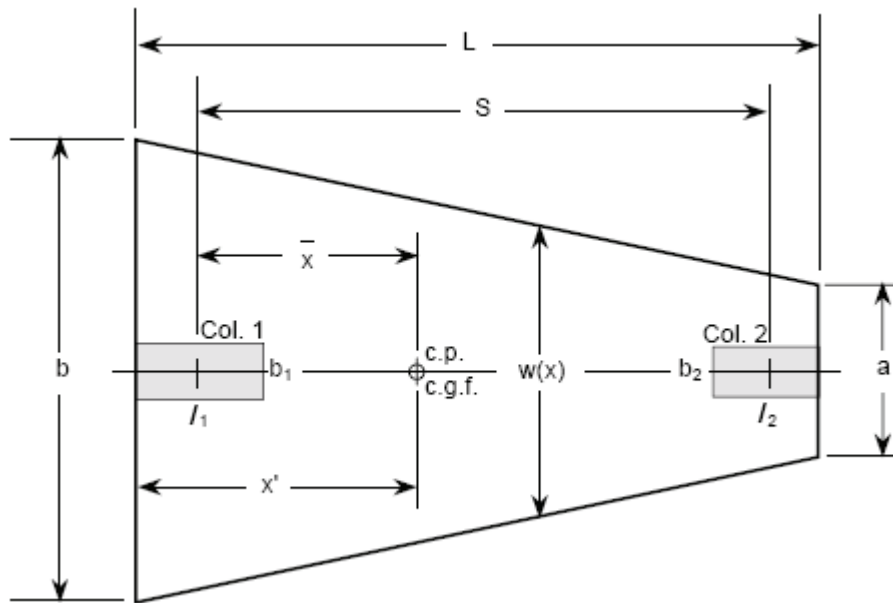

Allowable load  $P = P_1 + P_2$

Ultimate load  $P_u = [1.4DL_1 + 1.7LL_1] + [1.4DL_2 + 1.7LL_2]$

Ultimate ratio  $r_u = \frac{P_u}{P}$ , Ultimate applied pressure  $q_u = q_a \times r_u$

$$\Sigma M_{\text{col } 1} = 0 \quad \bar{x} = \frac{P_{u2} \times S}{P_u} \quad \text{and} \quad x' = \bar{x} + \frac{I_1}{2}$$

For a trapezoidal solution,  $\frac{L}{3} < x' < \frac{L}{2}$

For a trapezoidal solution,  $\frac{L}{3} < x' < \frac{L}{2}$

From trapezoidal geometry,

$$A = \frac{a+b}{2} L \quad \text{where } A = \text{Area} = \frac{P_u}{q_u}$$

$$\text{and} \quad x' = \frac{L}{3} \left( \frac{2a+b}{a+b} \right)$$

From these equations, we solve for a and b

## 5. SOIL CONSOLIDATION EQUATIONS

### 5.1 Instant Settlement of footings:

In Continuous footings:  $\Delta H = 8q(B^2) / Kv(B+1)^2$

In Square footings:  $\Delta H = 4q(B^2) / Kv(B+1)^2$

Where:

$K_v$  = modulus of subgrade reaction in Tons per cubic foot (Ton/ft<sup>3</sup>)

$B$  = footing width in feet,  $B$  is less than 20'

$q$  = applied stress at base of footings in Tons per square foot

$K_v = 50 - 80$  loose cohesionless soils

$K_v = 80 - 150$  in medium dense soils—most common value in design

$K_v = 150 - 230$  in Dense soils &

$K_v = 230 - 300$  in very dense soils

or

$S_i$  = immediate settlement of a point on the surface

$C_s$  = shape and rigidity factor

$q$  = equivalent uniform stress on the footing (total load/footing area)

$B$  = characteristic dimension of the footing

$\nu$  = Poisson's ratio

$E_u$  = undrained elastic modulus (Young's modulus)

$$S_i = C_s q B \left( \frac{1 - \nu^2}{E_u} \right)$$

### 5.2 Primary Consolidation:

$$S = (C_c / (1 + e_0)) H \times \text{Log}(\sigma_0 + \Delta q) / \sigma_0 \quad \text{or}$$

$$s_c = \frac{C_c H}{1 + e_0} \log \left( \frac{\sigma'_0 + \Delta q}{\sigma'_0} \right)$$

### 5.3 Overconsolidated Soils

Settlement of Overconsolidated soils Case 1: ( $\sigma_f < P_c$ )

$$\Delta H = (C_r / (1 + e_0)) H \times \text{Log } P_c / \sigma_0 \quad \text{or}$$

$$s_c = \frac{C_r H}{1 + e_0} \log \left( \frac{\sigma'_0 + \Delta q}{\sigma'_0} \right)$$

Settlement of Overconsolidated soils Case 2: ( $\sigma_f > P_c$ )

$$\Delta H = (C_r / (1 + e_0)) H \times \text{Log}(P_c / \sigma_0) + (C_c / (1 + e_0)) H \times \text{Log}(\sigma_f / \sigma_0) \quad \text{or}$$

$$s_c = \left( \frac{H}{1 + e_0} \right) \left( C_r \log \left( \frac{P_c}{\sigma'_0} \right) + C_c \log \left( \frac{\sigma'_0 + \Delta q}{P_c} \right) \right)$$

## 5.4 Time rate of settlement (i=immediate, c=consolidation, & s=secondary)

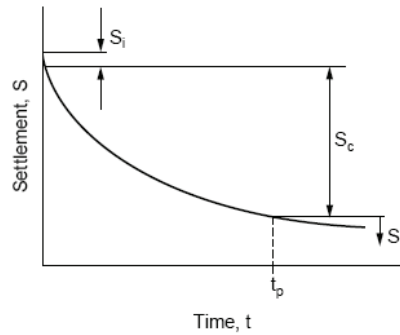

### 5.41 Coefficient of consolidation, $C_v$ :

$$c_v = \frac{k(1 + e_o)}{\gamma_w a_v}$$

$k$  = hydraulic conductivity  
 $\gamma_w$  = unit weight of water  
 $e_o$  = initial void ratio  
 $a_v = -de/d\sigma'_v$  = coefficient of compressibility

$$Z = \frac{z}{H_{dr}}$$

$$T = \frac{c_v t}{H_{dr}^2}$$

$z$  = depth below top of the compressible stratum  
 $H_{dr}$  = length of the longest pore water drainage path

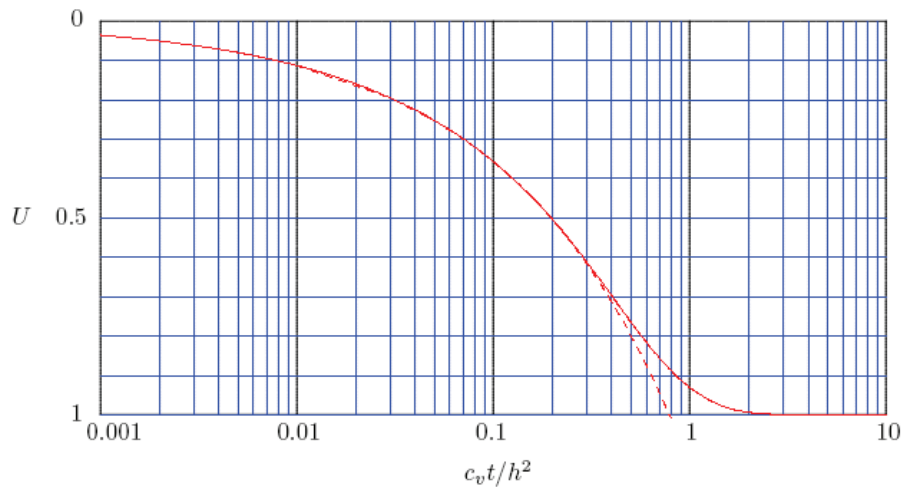
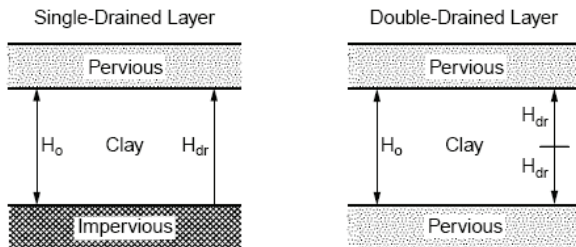

## 6. RETAINING STRUCTURES:

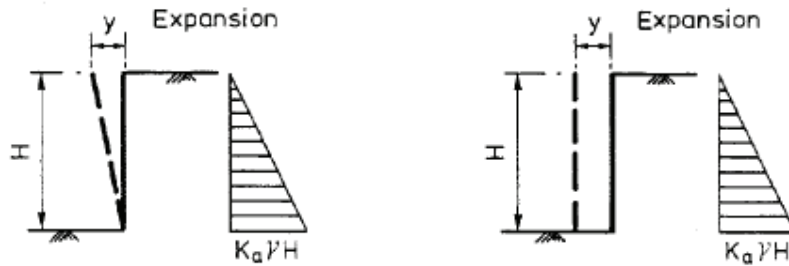

(i) Active State

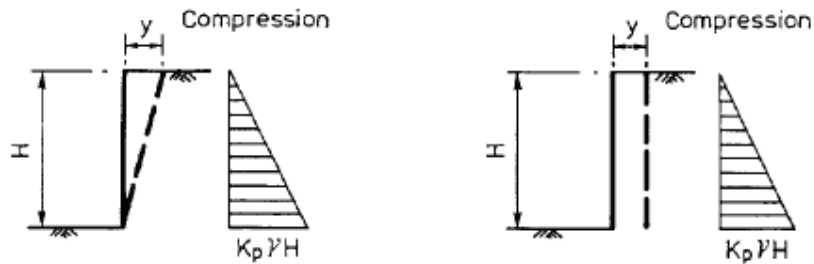

(ii) Passive State

(a) Rigid Retaining Wall Free to Translate or Rotate about Its Base

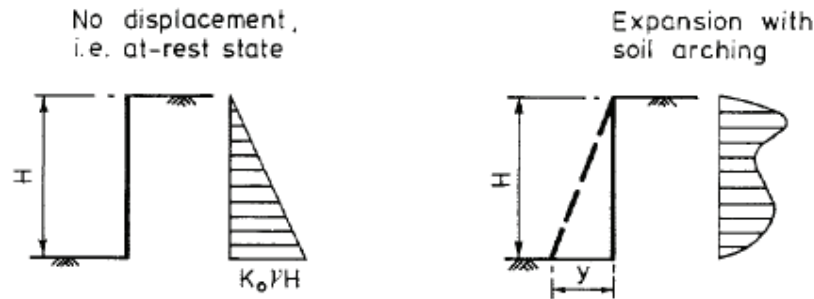

(b) Restrained Rigid Wall

(c) Top of Wall Restrained

### 6.1 Horizontal Stresses: Active, At Rest and Passive

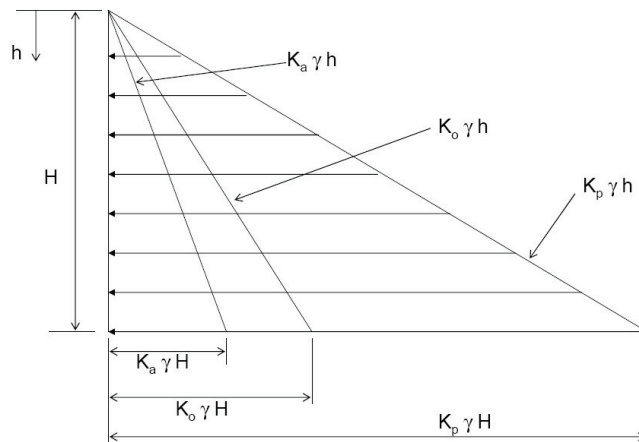



## 6.2 Basement Wall with surcharge:

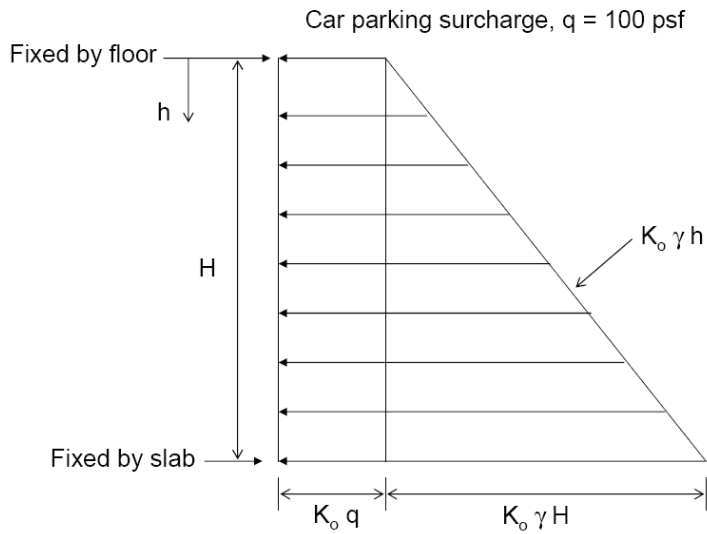

## 6.3 Braced Excavations:

At Rest Condition-The Struttred system is restrained.

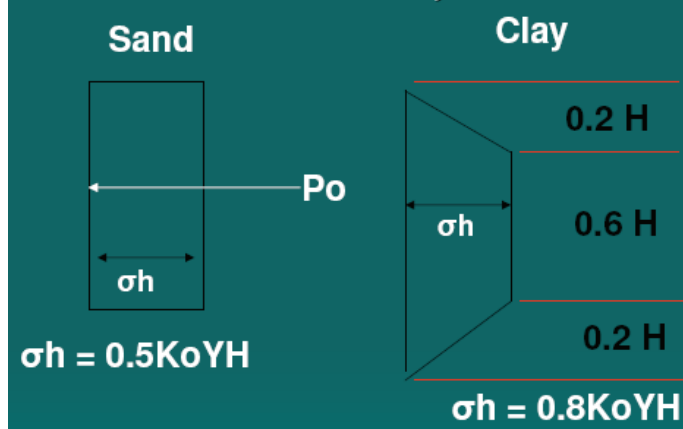

## Braced Excavations-Active Condition

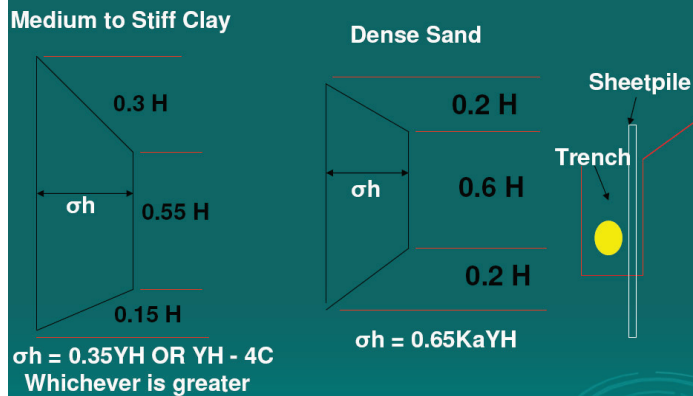

## 6.4 Forces on Struts:

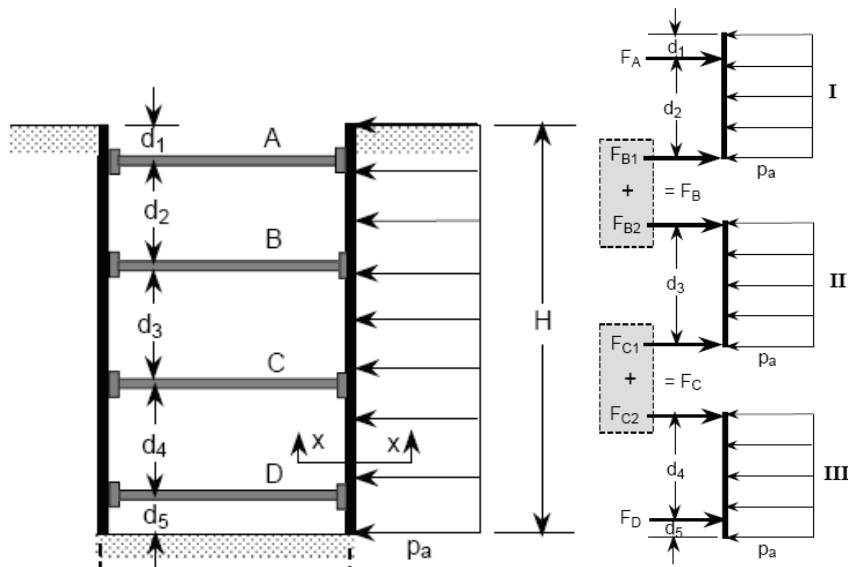

Note that the first strut A must be placed at a depth  $d_1 < z_c$  (depth of tension

crack) where  $z_c = \frac{2c}{\gamma}$ .

### Forces on Struts and Selection of Section

(Designed as column, pinned at both ends)

- 1) Draw the pressure diagram  $p_a$
- 2) Assume that the sheet pile is hinged at all levels of struts
- 3) Calculate  $F_A, F_{B1}, F_{B2}, F_{C1}, F_{C2},$  and  $F_D$  which are the reaction in the load distributions I, II and III.
- 4) The loads in the struts are calculated as:

$$P_A = (F_A) \times s$$

$$P_B = (F_{B1} + F_{B2}) \times s$$

$$P_C = (F_{C1} + F_{C2}) \times s$$

$$P_D = (F_D) \times s$$

### Maximu Moment on Sheet Pile and selection of Section

- 1) For each of the load distributions I, II and III find  $M_{max}$  i.e. where the shear is equal to zero.
- 2) The design moment for the sheet pile is the maximum of step (1)
- 3) Calculate the section modulus  $S = \frac{M_{max}}{\sigma_{all}}$  where  $\sigma_{all}$  = allowable stress for sheet pile
- 4) Select the sheet pile section based on S in Step 3

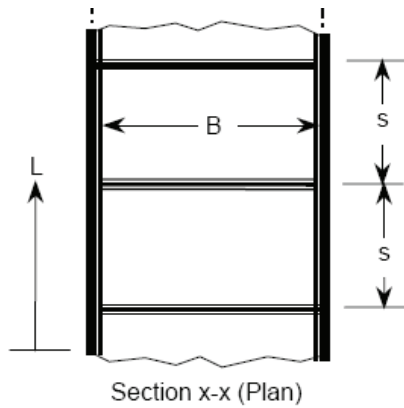

**Maximu Moment on Wales and selection of Section**  
 (Designed as beams pinned at the struts)

At level A:  $M_{A, \max} = \frac{F_A (s^2)}{8}$

At level B:  $M_{B, \max} = \frac{(F_{B1} + F_{B2}) (s^2)}{8}$

At level C:  $M_{C, \max} = \frac{(F_{C1} + F_{C2}) (s^2)}{8}$

At level D:  $M_{D, \max} = \frac{F_D (s^2)}{8}$

**Bottom Heave Calculations:**

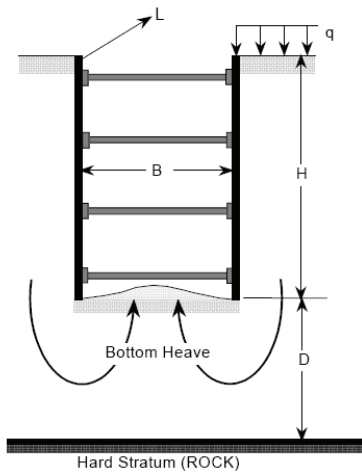

Safety Factor against bottom heave  $SF_H \geq 1.5$

If  $D > 0.7 B$

$$SF_H = \frac{1}{H} \left( \frac{5.7 c}{\gamma - \frac{c}{0.7B}} \right)$$

If  $D \leq 0.7 B$

$$SF_H = \frac{1}{H} \left( \frac{5.7 c}{\gamma - \frac{c}{0.7B}} \right)$$

OR

$$SF_H = \frac{c N_c}{\gamma H + q}$$

Whichever is larger

## 6.5 Cantilever Sheetpiles in Sand

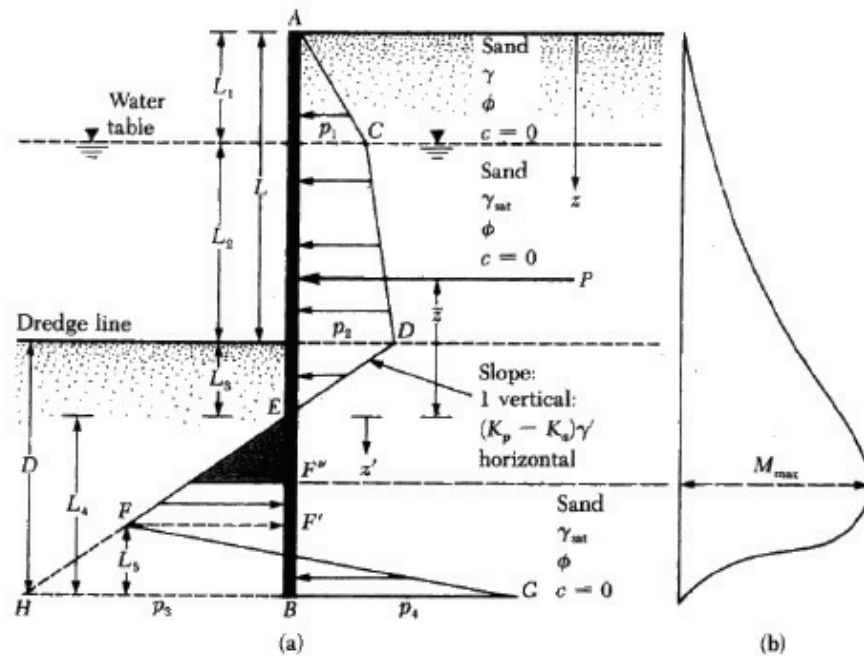

(a) Sheet Pile in Sand with dimensions and pressure distribution  
 (b) Moment distribution over the sheet pile.

1. Calculate:  $k_a = \tan^2\left(45 - \frac{\phi}{2}\right)$  and

$$k_p = \frac{1}{k_a} \quad \text{Note: Some designers use } k_{p(\text{Design})} = \frac{k_p}{\text{SF}} \text{ where SF} = 1.5 - 2.0$$

2. Calculate:  $p_1 = \gamma L_1 k_a$  and

$$p_2 = (\gamma L_1 + \gamma' L_2) \times k_a, \quad \gamma' = \gamma_{\text{SAT}} - \gamma_w$$

3. Calculate:  $L_3 = \frac{p_2}{\gamma(k_p - k_a)}$

4. Calculate:  $P = \text{Area ACDE} = \frac{1}{2} p_1 L_1 + p_1 L_2 + \frac{1}{2} (p_2 - p_1) L_2 + \frac{1}{2} p_2 L_3$

5. Calculate:  $\bar{z}$  by taking moment about E of area ACDE =  $P \bar{z}$

6. Calculate:  $p_5 = (\gamma L_1 + \gamma' L_2) \times k_p + \gamma' L_3 (k_p - k_a)$

7. Calculate:  $L_4$  by trial and error from the equation:

$$L_4^4 + A_1 L_4^3 - A_2 L_4^2 - A_3 L_4 - A_4 = 0,$$

where,

$$A_1 = \frac{p_5}{\gamma(k_p - k_a)}$$

$$A_2 = \frac{8P}{\gamma(k_p - k_a)}$$

$$A_3 = 6P \left[ \frac{2\bar{z}\gamma(k_p - k_a) + p_5}{\gamma(k_p - k_a)^2} \right]$$

$$A_4 = P \left[ \frac{(6\bar{z}p_5 + 4P)}{\gamma(k_p - k_a)^2} \right]$$

8. Calculate:  $p_4 = p_5 + \gamma L_4(k_p - k_a)$  ,  $p_3 = \gamma L_4(k_p - k_a)$  and

$$L_5 = \frac{(p_3 L_4 - 2P)}{(p_3 + p_4)}$$

Draw the sheet pile (similar to page 1) with the estimated values in steps 1-8

9. Calculate:  $D = 1.3 \text{ to } 1.6(L_3 - L_4)$

10. Calculate:  $z' = \sqrt{\frac{2P}{\gamma'(k_p - k_a)}}$

11. Calculate:  $M_{\max} = P(\bar{z} + z') - \left[ \frac{1}{2} \gamma' z'^2 (k_p - k_a) \right] \left( \frac{1}{3} \right) z'$

12. Calculate:  $S = \frac{M_{\max}}{\sigma_{\text{all}}}$

where  $S$  = Minimum section modulus of sheet pile  
 $\sigma_{\text{all}}$  = allowable stress for sheet pile

## 6.6 Cantilever Sheetpiles in Clay

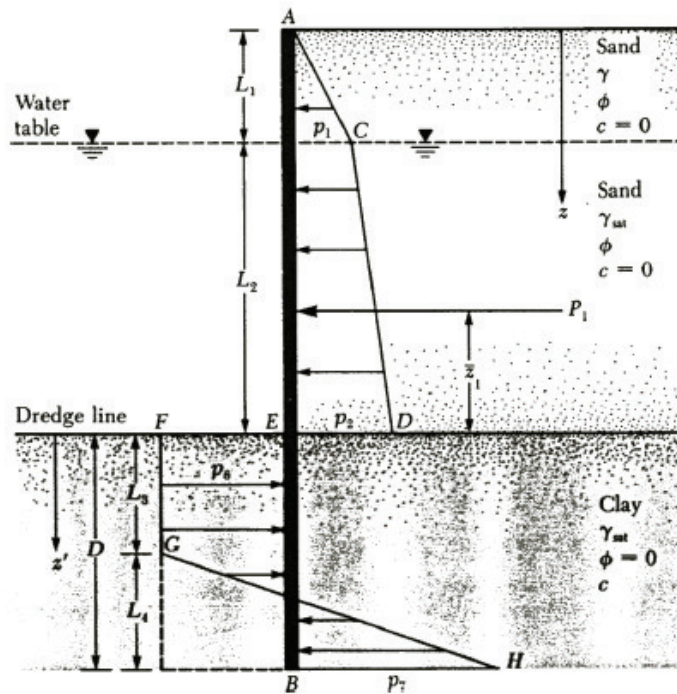

Sheet Pile in Clay with dimensions and pressure distribution

**Design Steps (refer to figure above for terms)**

1. Calculate:  $k_a = \tan^2\left(45 - \frac{\phi}{2}\right)$

2. Calculate:  $p_1 = \gamma L_1 k_a$  and

$$p_2 = (\gamma L_1 + \gamma' L_2) \times k_a \quad \text{where } \gamma' = \gamma_{SAT} - \gamma_w$$

3. Calculate:  $\frac{1}{2} p_1 L_1 + p_1 L_2 + \frac{1}{2} (p_2 - p_1) L_2$

4. Calculate:  $\bar{z}_1$  by taking moment about E of area ACDE =  $P_1 \bar{z}_1$

5. Calculate: D by the following equation :

$$D^2 \left[ 4c - (\gamma L_1 + \gamma' L_2) \right] - 2DP_1 - \frac{P_1(P_1 + 12c\bar{z}_1)}{(\gamma L_1 + \gamma' L_2) + 2c}$$

6. Calculate:  $D_{actual} = 1.3 \text{ to } 1.6 D$

7. Calculate:  $p_6 = 4c - (\gamma L_1 + \gamma' L_2)$  and  $p_7 = 4c + (\gamma L_1 + \gamma' L_2)$

8. Calculate:  $L_4 = \frac{(Dp_6 - P_1)}{4c}$  and

Draw the sheet pile (similar to page 1) with the estimated values in steps 1-8

9. Calculate:  $z' = \frac{P_1}{p_6}$

10. Calculate:  $M_{max} = P_1(\bar{z}_1 + z') - \frac{p_6 z'^2}{2}$

11. Calculate:  $S = \frac{M_{max}}{\sigma_{all}}$

where  $S$  = Minimum section modulus of sheet pile  
 $\sigma_{all}$  = allowable stress for sheet pile

## 6.6 Anchored Sheetpiles in Sand (Also called Bulkheads)

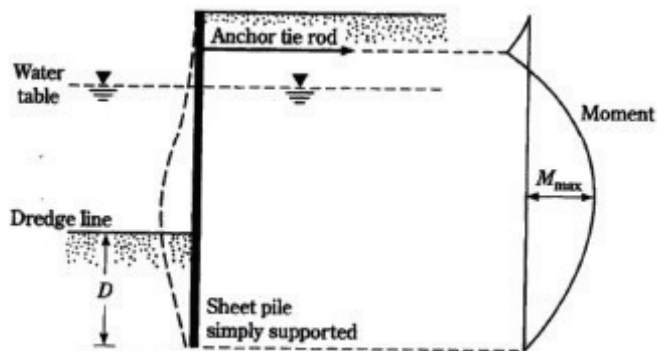

Deformation and moment distribution over the sheet pile.

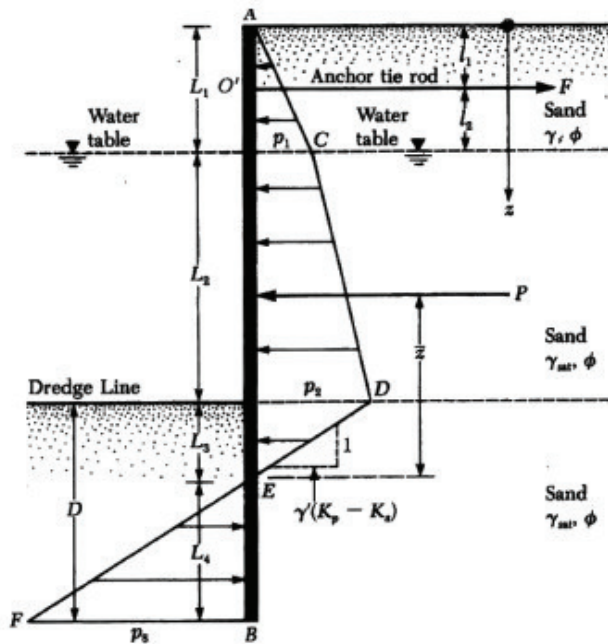

Sheet Pile in Sand with dimensions and pressure distribution

Design Steps (refer to figure above for terms)

1. Calculate:  $k_a = \tan^2\left(45 - \frac{\phi}{2}\right)$  and

$$k_p = \frac{1}{k_a} \quad \text{Note: Some designers use } k_{p(\text{Design})} = \frac{k_p}{\text{SF}} \text{ where SF} = 1.5 - 2.0$$

2. Calculate:  $p_1 = \gamma L_1 k_a$  and  $p_2 = (\gamma L_1 + \gamma' L_2) \times k_a$ , where  $\gamma' = \gamma_{\text{SAT}} - \gamma_w$

3. Calculate:  $L_3 = \left[ \frac{p_2}{\gamma' (k_p - k_a)} \right]$

4. Calculate:  $P = \text{Area ACDE} = \frac{1}{2} p_1 L_1 + p_1 L_2 + \frac{1}{2} (p_2 - p_1) L_2 + \frac{1}{2} p_2 L_3$

5. Calculate:  $\bar{z}$  by taking moment about E of area ACDE =  $P\bar{z}$

6. Calculate:  $L_4$  by trial and error from the equation:

$$L_4^3 + 1.5 L_4^2 (L_2 + L_2 + L_3) - \frac{3P \left[ (L_1 + L_2 + L_3) - (\bar{z} + L_1) \right]}{\gamma' (k_p - k_a)} = 0$$

7. Calculate:  $D = L_3 + L_4$  ( $D_{\text{actual}} = 1.3 \text{ to } 1.6 D$ )

8. Calculate: Force in anchor rod  $F = P - \frac{1}{2} \left[ \gamma' (k_p - k_a) \right] \times L_4^2$

9. Calculate:  $p_8 = \gamma'(k_p - k_a) \times L_4$  and

Draw the sheet pile (similar to page 1) with the estimated values in steps 1-8

10. Calculate:  $z_m$  for zero shear, hence,  $M_{max}$  by :

$$\frac{1}{2} p_1 L_1 - F + p_1(z_m - L_1) + \frac{1}{2} k_a \gamma' (z_m - L_1)^2 = 0$$

$$L_1 < z_m < (L_1 + L_2)$$

11. Calculate:  $M_{max}$  by summing moments at a point  $z_m$  from surface.

12. Calculate:  $S = \frac{M_{max}}{\sigma_{all}}$

### 6.7 Anchored Sheetpiles in Clay (Also called Bulkheads)

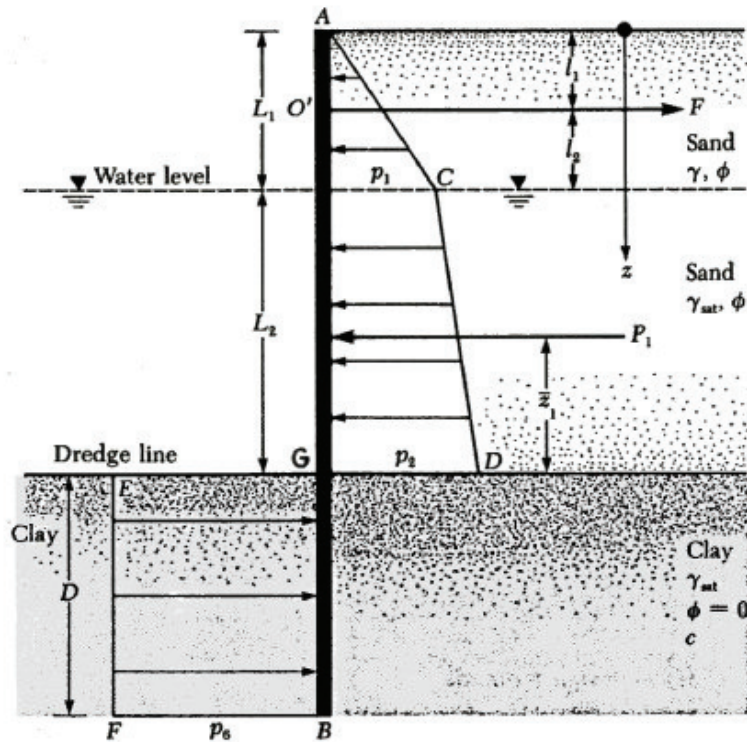

Anchored Sheet Pile in Clay with dimensions and pressure distribution

Design Steps (refer to figure above for terms)

1. Calculate:  $k_a = \tan^2\left(45 - \frac{\phi}{2}\right)$

2. Calculate:  $p_1 = \gamma L_1 k_a$  and

$$p_2 = (\gamma L_1 + \gamma' L_2) \times k_a, \text{ where } \gamma' = \gamma_{SAT} - \gamma_w$$



3. Calculate:  $P_1 = \text{Area ACDG} = \frac{1}{2} p_1 L_1 + p_1 L_2 + \frac{1}{2} (p_2 - p_1) L_2$

4. Calculate:  $\bar{z}_1$  by taking moment about G of area ACDG =  $P_1 \bar{z}_1$

5. Calculate:  $p_6 = 4c - (\gamma L_1 + \gamma L_2)$

6. Calculate: D from the following equation:

$$p_6 D^2 + 2p_6 D(L_1 + L_2 - l_1) - 2P_1(L_1 + L_2 - l_1 - \bar{z}_1) = 0$$

7. Calculate: Force in anchor rod  $F = P_1 - p_6 D$

Draw the sheet pile (similar to page 1) with the estimated values in steps 1-6

8. Calculate:  $D_{\text{actual}} = 1.3 \text{ to } 1.6 D$ ,

9. Calculate:  $z_m$  for zero shear, hence,  $M_{\text{max}}$  by :

$$\frac{1}{2} p_1 L_1 - F + p_1 (z_m - L_1) + \frac{1}{2} k_a \gamma' (z_m - L_1)^2 = 0$$

$$L_1 < z_m < (L_1 + L_2)$$

10. Calculate:  $M_{\text{max}}$  by summing moments at a point  $z_m$  from surface.

11. Calculate:  $S = \frac{M_{\text{max}}}{\sigma_{\text{all}}}$

where  $S$  = Minimum section modulus of sheet pile  
 $\sigma_{\text{all}}$  = allowable stress for sheet pile

## 7. PILE FOUNDATIONS

### 7.1 Single Piles Equations:

$Q_u$  = Ultimate Pile Capacity

$Q_p$  = Load-capacity of pile point

$Q_s$  = Skin friction resistance

$L$  = Pile length

$q'$  = overburden pressure at pile tip

$D$  = Pile dimension

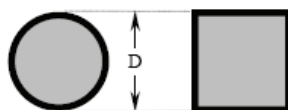

Pile cross-section

$A_p$  = Area of the pile cross-section

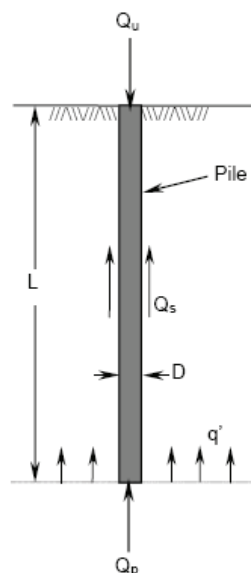

### Load-Capacity of Pile Point

$$Q_p = A_p q' N_q^*$$

or

$$Q_p = A_p q_l$$

whichever is smaller

$$\text{where } q_l (\text{kPa}) = 50 N_q^* \tan \phi$$

and  $N_q^*$  = Bearing capacity factor obtained from Fig. 1

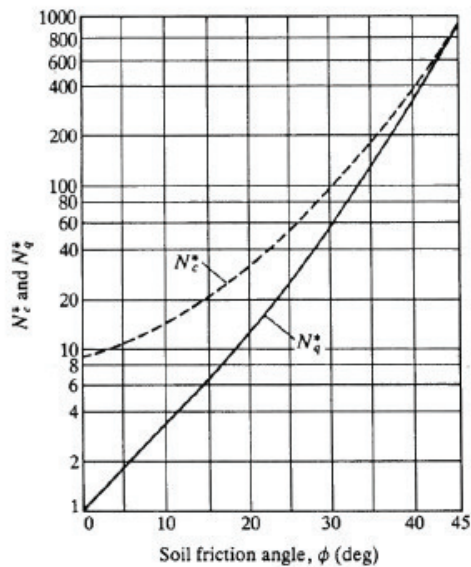

Fig. 1 Variation of  $N_c^*$  and  $N_q^*$  with  $\phi$

$$\left. \begin{aligned} Q_s(1) &= p L' f_{av} \\ Q_s(2) &= p (L - L') f \end{aligned} \right\} Q_s = Q_s(1) + Q_s(2)$$

where

$$f = K \sigma_v' \tan \delta \quad (\text{skin friction})$$

$\sigma_v'$  = overburden pressure

$$K = \text{lateral earth pressure} = 0.5 + 0.008 D_r \quad (D_r = \text{relative density in percent})$$

$\delta$  = friction angle between soil and pile (usually  $0.6\phi$ )

$p$  = perimeter of the pile

$f_{av}$  = average skin friction from 0 to  $L = f/2$

### Skin Friction Resistance

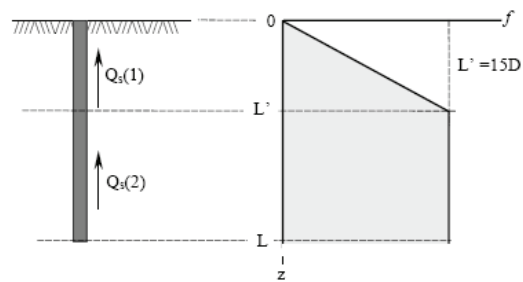

Fig. 2. Variations of skin friction with depth

## 7.2 Group capacity of piles:

### Efficiency of Pile Group

$$\text{Efficiency, } \eta = \frac{2(n_1 + n_2 - 2)d + 4D}{p n_1 n_2}$$

where the parameters are as defined in Fig. 3

Ultimate load capacity of pile group:

$$Q_u(g) = \Sigma Q_u * \eta$$

if  $\eta \geq 1.0$  use  $\eta = 1.0$

Allowable load capacity of pile group:

$$Q_a(g) = Q_u(g)/SF$$

where  $2.5 \leq SF \leq 4.5$

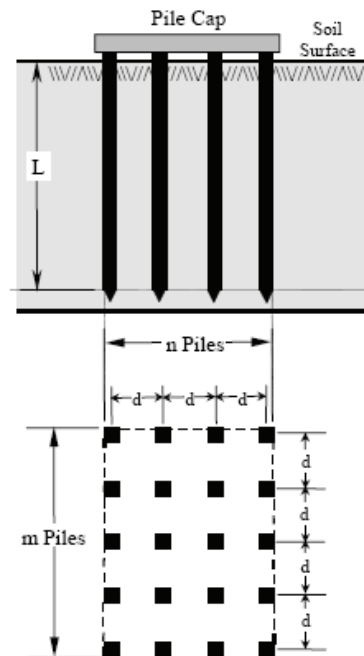

Fig. 3. Pile group

### Example:

Estimate the total load that the pile group shown below can carry. Note that the every single pile is identical to that in Examples 1 and 2.

#### SOLUTION:

Total load that the a single pile can carry  
 $Q = 844.73 \text{ kN}$  (Examples 1 and 2)

$m = 5$ ,  $n = 4$  and  $mn = 20$  piles

$$Q_T = 844.73 \times 20 = 16894.6 \text{ kN}$$

The efficiency of the group:

$$\eta = \frac{2(m + n - 2)d + 4D}{p m n}$$

$$\eta = \frac{2(5 + 4 - 2)(1.5) + 4(0.305)}{(4 \times 0.305) \times 5 \times 4}$$

$$= 0.91 \text{ (or 91\%)}$$

The total load that can be carried by  
 The pile group is, therefore

$$Q_{TG} = 16894.6 \times 0.91 = 15374.09 \text{ kN}$$

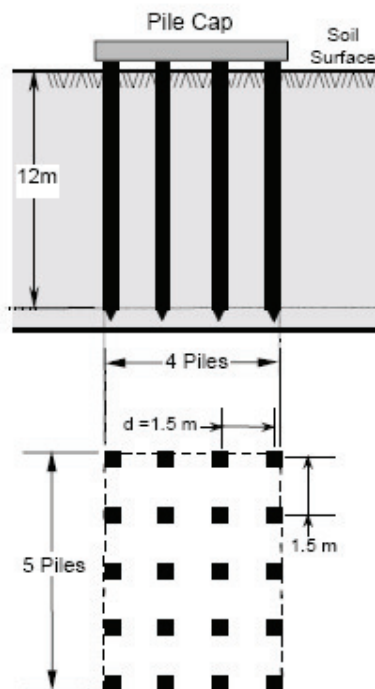

### 7.3 Settlement of Group Piles:

The settlement for group piles in coarse-grained soils from SPT and cone penetration tests can be estimated from:

$$\text{SPT: } \rho_{es} = \frac{360 \Delta \sigma_z I \sqrt{B_g}}{N_{cor}} \quad (\text{mm}) \quad (8.44)$$

$$\text{Cone } \rho_{es} = \frac{\Delta \sigma_z I B_g}{2 q_c} \quad (8.45)$$

where:  $I = 1 - 0.08 \frac{L}{B_g} \geq 0.5$ ,  $\Delta \sigma_z$  is the stress increase at a depth of  $\frac{2L}{3}$ , i.e.,

$$\left( \Delta \sigma_z \approx \frac{Q_a}{\left( B_g + \frac{2}{3}L \right) \left( L_g + \frac{2}{3}L \right)} \right)$$

$B_g$  and  $L_g$  are the width and length of the pile group,  $L$  is the embedded length of the pile, and  $q_c$  is the arithmetic average of the cone resistance over two pile diameters below the cone tip.

### 8. Post Tensioned Slabs:

Edge Lift:

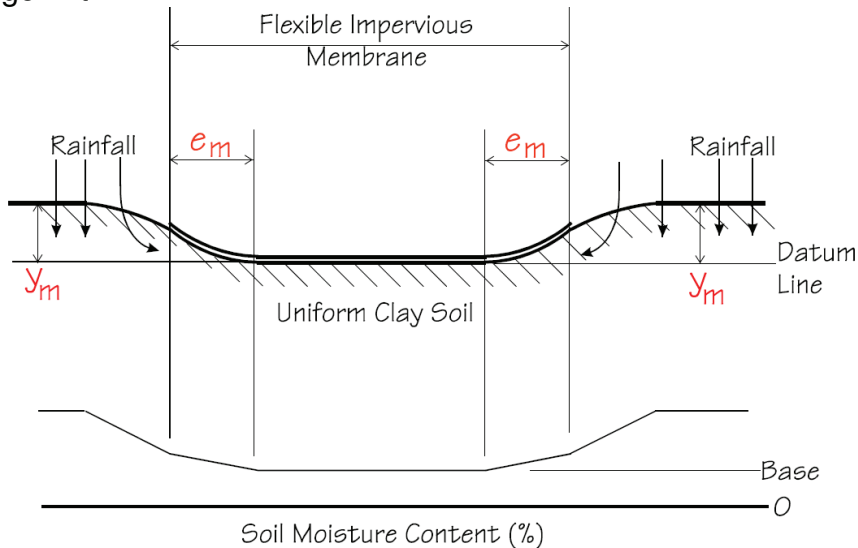

**Center Lift:**

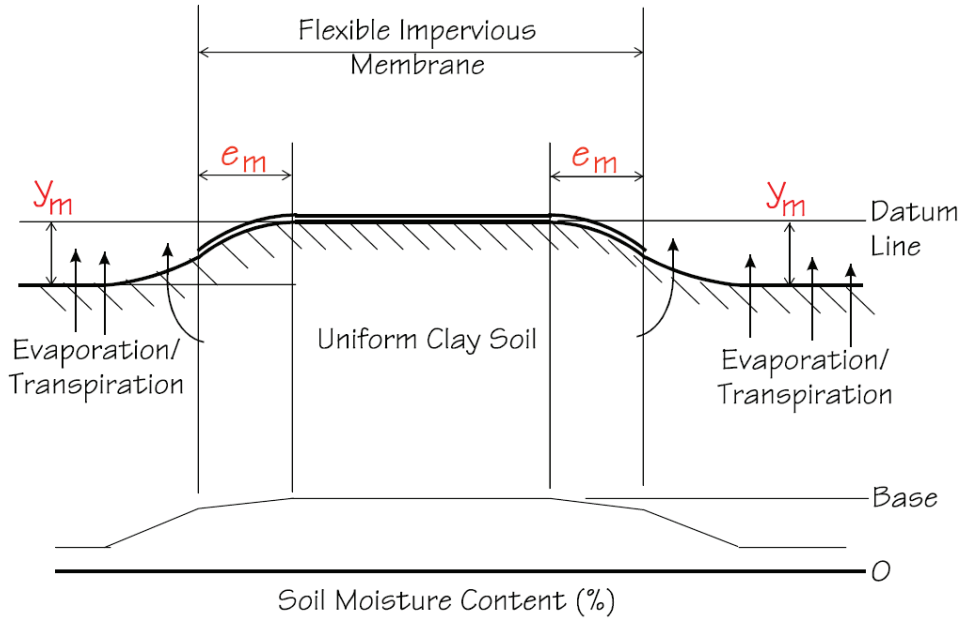

**Edge Lift**

- Soils are wetter at slab edge than at any point inside slab edge.

**Center Lift**

- Soils are drier at slab edge than at any point inside slab edge.

- Edge Moisture Variation Distance  $e_m$
- Thornthwaite Moisture Index (climate)
  - Soil Permeability
  - Vegetation

- Unrestrained Differential Swell  $y_m$
- Properties (activity) of clay
  - Depth of clay (active zone)
  - Soil suction

One set of  $e_m$  &  $y_m$  values established for each swell mode (edge and center lift)  
 Design cannot be done without these parameters

	Edge Lift	Center Lift
$e_m$	2.0 ft	5.0 ft
$y_m$	0.75 in	3.0 in

The Structural Engineer also needs  $K_v$  (given in immediate settlement section), effective  $PI$  (pp 138 of Geotechnical DVD book) and other climatic constants that are from building codes(given).

## 9. Asphalt Mix Design:

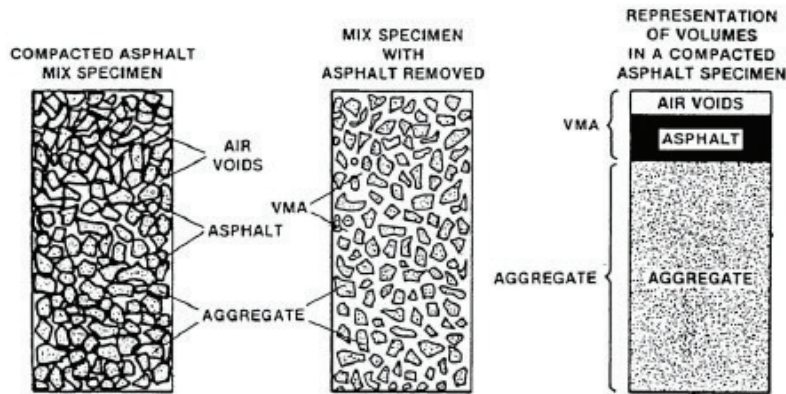
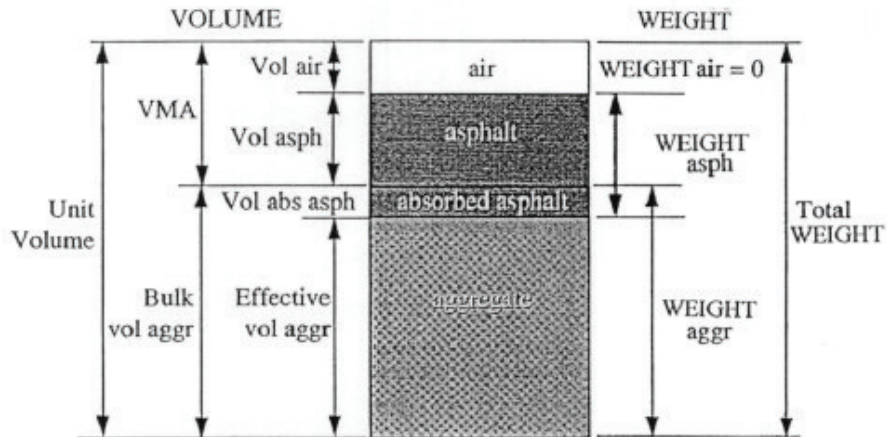

### LOW STABILITY

Causes	Effects
Excess binder in HMA	Washboarding, rutting, and flushing or bleeding
Excess medium size sand in HMA	Tenderness during rolling and for a period after construction, and difficulty in compacting
Rounded aggregate, little or no crushed surfaces	Rutting and channeling

### POOR DURABILITY

Causes	Effects
Low binder content	Dryness or ravelling
High void content through design or lack of compaction	Early hardening of binder followed by cracking or disintegration
Water susceptible (hydrophilic) aggregate in HMA	Films of binder strip from aggregate leaving an abraded, ravelled, or mushy pavement

### MIX TOO PERMEABLE

Causes	Effects
Low binder content	Thin binder films will cause early aging and ravelling
High void content in design HMA	Water and air can easily enter pavement causing oxidation and disintegration
Inadequate compaction	Will result in high voids in pavement leading to water infiltration and low strength

### POOR FATIGUE RESISTANCE

Causes	Effects
Low asphalt binder content	Fatigue cracking
High design voids	Early aging of binder followed by fatigue cracking
Lack of compaction	Early aging of binder followed by fatigue cracking
Inadequate pavement thickness	Excessive bending followed by fatigue cracking

### AC Mix design Formulas:

$$\%G_{mm} = 100x \frac{G_{mb} \times h_d}{G_{mm} \times h_i}$$

$G_{mb}$  = bulk specific gravity at  $N_{des}$   
 $G_{mm}$  = theoretical maximum specific gravity at  $N_{des}$   
 $h_d$  = height of specimen at  $N_{des}$   
 $h_i$  = height of specimen at  $N_{ini}$

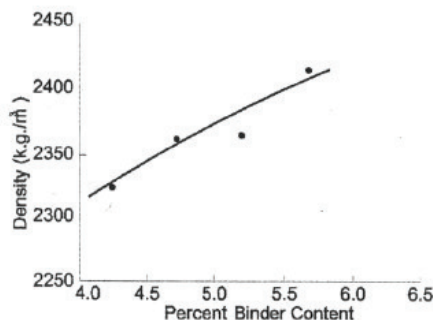
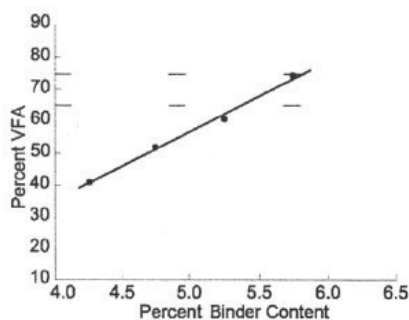
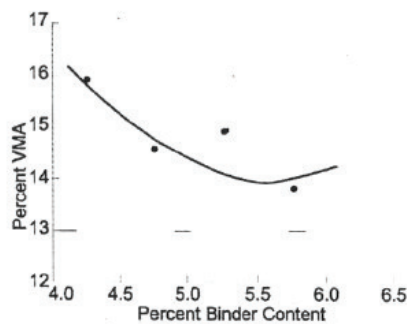
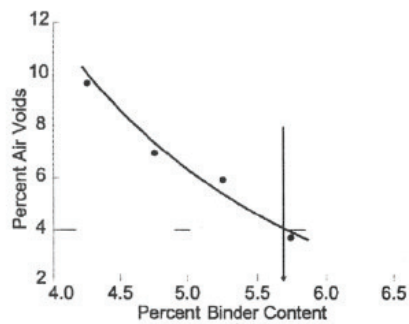

When weighing in Water:

$$\text{Maximum Specific Gravity } (G_{mm}) = \frac{A}{A - (C - B)}$$

where:

$A$  = weight of oven dry sample in air, g

$B$  = weight of container in water, g

$C$  = weight of container and sample in water, g

When weighing in Air:

$$\text{Maximum Specific Gravity } (G_{mm}) = \frac{A}{A + D - E}$$

where:

$A$  = weight of oven dry sample in air, g

$D$  = weight of container filled with water at 77°F, g

$E$  = weight of container filled with sample and water at 77°F, g

$$\text{Bulk Specific Gravity } (G_{mb}) = \frac{A}{B - C}$$

where:

$A$  = weight of specimen in air, g

$B$  = weight of surface-dry specimen in air, g

$C$  = weight of specimen in water, g

$$\text{Percent Water Absorbed by Volume} = \left( \frac{B - A}{B - C} \right) \times 100$$

**Open Graded Mixtures:**

$$G_{mb} = \frac{A}{B - E - \left( \frac{B - A}{F_T} \right)}$$

where:

$A$  = weight of dry specimen in air, g

$B$  = weight of dry, sealed specimen, g

$E$  = weight of sealed specimen in water, g

(weight of absorbed water is subtracted)

$F_T$  = apparent specific gravity of plastic sealing material at 77°F

$$\text{Water Absorption, percent} = \left( \frac{A_1 - A}{A} \right) \times 100$$

where:

$$\text{Dust Proportion} = \frac{P_{200}}{P_{be}}$$

$P_{200}$  = aggregate content passing the No. 200 sieve, percent by weight of aggregate

$P_{be}$  = effective binder content, percent by total weight of mixture

$$\text{Absorbed Asphalt } (P_{ba}) = 100 \times \left( \frac{G_{se} - G_{sb}}{G_{sb} \times G_{se}} \right) \times G_b$$

where:

$G_{se}$  = effective specific gravity of aggregate

$G_{sb}$  = bulk specific gravity of aggregate

$G_b$  = specific gravity of binder



$$\text{Air Voids } (Va) = 100 \times \left( \frac{Gmm - Gmb}{Gmm} \right)$$

$$\text{Voids in the Mineral Aggregate } (VMA) = 100 - \left( \frac{Gmb \times Ps}{Gsb} \right)$$

where:

$Gmm$  = Maximum Specific Gravity of HMA

$Gmb$  = Bulk Specific Gravity of HMA

where:

$Gmb$  = Bulk Specific Gravity of HMA

$Gsb$  = Bulk Specific Gravity of aggregate  
(Obtained from design mix formula)

$Ps$  = Aggregate, percent by total weight of HMA

The percent of aggregate by total weight of HMA ( $Ps$ ) is determined by subtracting the actual binder content by total weight of HMA ( $Pb$ ) supplied on the design mix formula from 100.

$$Ps = 100 - Pb$$

$$\text{Voids Filled with Asphalt } (VFA) = \left( \frac{VMA - Va}{VMA} \right) \times 100$$

## 10. Concrete Mix Design:

$$\text{Free Moisture } (\%) = \frac{Ww - Ws}{Wd} \times 100$$

Where:  $Ws$  = Saturated surface-dry weight.

$$\text{Absorbed Moisture } (\%) = \frac{Ww - Wd}{Wd} \times 100$$

### Fineness modulus:

The standard size sieves are 6 inch, 3 inch, 1 1/2 inch, 3/4 inch, 3/8 inch, No. 4, No. 8, No. 16, No. 30, No. 50, and No. 100. In this series, the size of each opening, beginning with the 100-mesh sieve, is one-half that of the next larger size used. The percent of material passing the 100-mesh sieve is not used in calculating the fineness modulus. For example, the fineness modulus of a fine aggregate, such as would be used in concrete, may be as follows:

#### FINE AGGREGATE - SAND, GRADING A

Sieve Size	Percent Retained	Cumulative Percent Retained
3/8" (9.5 mm)	0.0	0.0
No. 4 (4.75 mm)	0.0	0.0
No. 8 (2.36 mm)	12.0	12.0
No. 16 (1.18 mm)	15.0	27.0
No. 30 (0.600 mm)	32.0	59.0
No. 50 (0.300 mm)	18.0	77.0
No. 100 (0.150 mm)	13.0	90.0
No. 200 (0.075 mm)	10.0	100.0 (Not Include.)
		Total = 265.0

$$\frac{2.65}{100} = 2.65 = \text{F.M. (Ans.)}$$

### Yield:

The yield of concrete produced per batch shall be calculated as follows:

$$Y = \frac{(N \times 94) + W_f + W_c + W_w}{W}$$

Where: Y = Yield of concrete produced per batch, in cu. ft.,

N = Number of bags of cement in the batch,

94 = Net weight of a bag of cement, in lbs.,

W<sub>f</sub> = Total weight of fine aggregate in batch in condition used, in lbs.,

W<sub>c</sub> = Total weight of coarse aggregate in batch in condition used, in lbs.,

W<sub>w</sub> = Total weight of mixing water added to batch, in lbs., and

W = Weight of concrete, in lbs. per cu. ft.

### Relative Yield:

$$R_y = \frac{Y}{Y_d}$$

Y = Yield of concrete produced per batch, in yd<sup>3</sup>,

Y<sub>d</sub> = Theoretical Yield (yd<sup>3</sup>)

NOTE: A value for R<sub>y</sub> greater than 1.00 indicates an excess of concrete being produced, while a value less than 1.00 indicates the batch to be "short" of its designed volume.

Where: R<sub>y</sub> = Relative Yield of concrete

### (a) Unit Weight

The net weight of the concrete shall be calculated by subtracting the weight of the measure used in the test from the gross weight. The unit weight shall be calculated by multiplying the net weight by the factor for the measure used. The method of determining this factor is given in AASHTO T121.

### Modulus of Rupture:

= (7.5√f'<sub>c</sub>) or

$$\text{Modulus of Rupture, in psi} = \frac{3WL}{2bd^2}$$

Where: W = Maximum indicated load, in lbs.,

L = Distance between supports, in in., and

b & d = Breadth and depth of beam, in in.

With a 6" x 6" x 40" beam, this formula resolves to:  $\frac{72W}{432} = \frac{W}{6}$

Therefore, 1/6 of the gage reading equals the modulus of rupture of the tested specimen, in lbs. per sq. in.